

SETTING FLANGE

flat gaskets for flange





Carrara S.p.a. believes in the modern meaning of SUPPLIER: a partner that actively takes part in creating value. This value is the result of expertise and flexibility, in addition to the ability to innovate and build strong relationships with Customer.

Founded in 1961, Carrara boasts years of experience in offering a complete product range of flat gaskets, for more general applications as well as more challenging ones.

The product range spans the following product lines:

- PLANIGRAPH®
Graphite gasket sheets and gaskets
- PLANIFLON®
PTFE sheets, tapes and gaskets
- PLANIFLEX®
Asbestos Free gasket sheets and gaskets
- PLANIX®
Rubber gasket sheets and gaskets

Table of contents

0.0	Company	Global Sealing Solutions	pag.	4
1.0	PLANIGRAPH®	Graphite	pag.	6
2.0	PLANIFLON®	PTFE	pag.	12
3.0	PLANIFLEX®	Compressed fibre (CSF)	pag.	18
4.0	PLANIX®	Rubber and other materials	pag.	22
5.0	Quality	Summary tables and other utilities	pag.	26

The data shown in the technical data sheets have been obtained from tests carried out at Carrara S.p.a laboratories, from tests performed at third-party laboratories and from the experience of using the products in industrial applications. Correct product selection and installation are determining factors for product functionality. Carrara S.p.a. assumes no responsibility for damage to property and persons caused by improper use, incorrect use or non-optimal use of its products. Carrara S.p.a. reserves the right to change the technical data shown in this catalogue without having to communicate any changes to third parties.

Carrara

Carrara Global Sealing Solutions, committed to Partnership

4 Operating Divisions

- Sealing systems and valve components
- Industrial Sealing Systems
- Environmental Services
- Technical threads for industry

Carrara is Partner to the main producers of process components for fluid control and is certified by the main International EPCs and main Oil and Gas Players to provide sealing systems and Environmental Services.

- 20.000 m² of covered surface area
- 160 employees
- Patented products
- Frame Agreements with International Customers

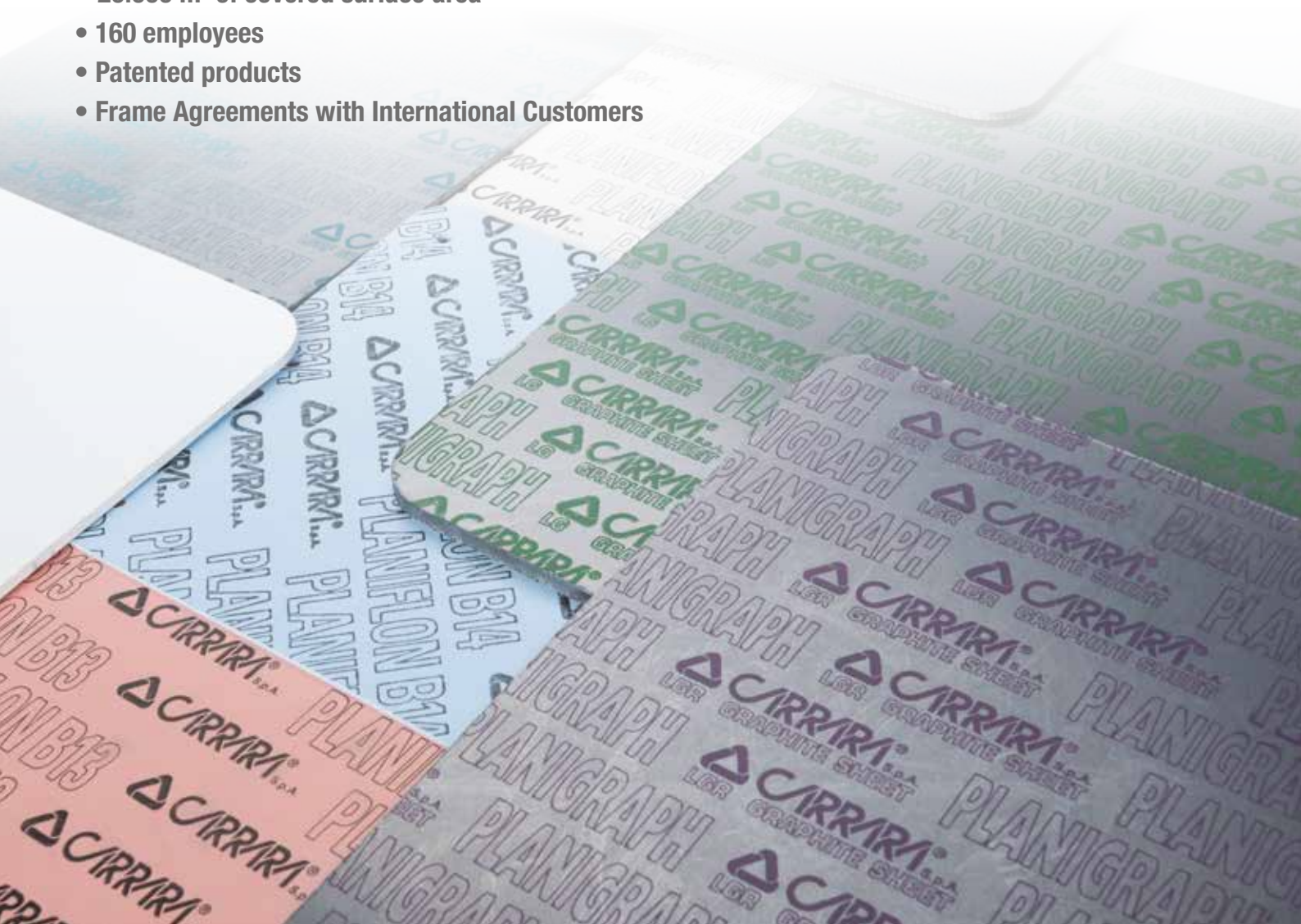



Mission

- Satisfying our Customers by producing efficient Sealing Systems.
- Providing our Customers with the best technical, logistic and price solution.
- Committing to establishing long-term business Partnerships with Customers and working with them striving for continuous improvement.

Assets

To achieve its mission, Carrara Global Sealing Solutions has provided itself with space for logistics, equipment, management software and human resources adapted to the needs of an increasingly competitive and demanding market.

- The vast factory surface area ensures an extremely logical flow of raw materials, semi-finished goods and goods, guaranteeing maximum efficiency.
- The equipment for handling, processing, quality control and packaging is all integrated into a process that allows the management of high products volume while maintaining traceability and compliance with quality standards and delivery terms agreed with the Customer.
- The use of SAP and advanced order management software allows to minimise the manual processing of data in order to guarantee integrity at every stage of the process.
- Staff expertise and skill are constantly checked and integrated within a structured plan aimed at producing continuous improvement.



Sealing Solutions

Carrara offers sealing solutions to maximise performance and reduce maintenance requirements. Safety, efficiency and added value are the driving force behind the R&D department, which is responsible for selecting materials and initiating the production of new products and upgrades.

Partnership

Carrara Global Sealing Solutions, a Partner to win together!

Carrara works with Customers in a globalised and competitive market to win with them and alongside them. This is why Carrara offers expertise and reliability in its modern role as Supply Chain Partner.





PLANIGRAPH®

Graphite





METALBOND PLANIGRAPH®

Metalbond Planigraph® minimises emissions because it avoids infiltrations between sheet and graphite and the erosion of the inner edge, preventing the graphite from coming into contact with the fluid.

- **Style I** 
 - With SS316L grade stainless steel perforated sheet reinforcement and inner ring.
- **Style IE** 
 - With SS316L grade stainless steel perforated sheet reinforcement and inner and outer rings.



-  **Temperature**
Metalbond Planigraph® is applicable both in very low temperatures at -200°C and at very high temperatures up to 550°C with non-oxidising fluids and up to 400°C with weak oxidising fluids and hot air.
-  **Pressure range**
Metalbond Planigraph® is applicable on RF flanges up to 600 psi class while on other flanges it is applicable at very high pressure.
-  **pH Range**
Metalbond Planigraph® is applicable across the whole range 0÷14 with the exception of strong oxidants.

Certifications

- TA LUFT VDI 2440
- Fire Test



Metalbond Multi

Metalbond Planigraph® Multi is the **Low Emission and Fire Safe** approved gasket able to provide sealing of almost all industrial fluids and gases while minimising the need to stock spare parts.

The special external profile of the gasket actually allows **Metalbond Planigraph® Multi** to be used on ASME RF flanges for classes 150-300-600 up to the 3 inch size and for classes 150-300 for larger sizes.



PLANIGRAPH® GRAPHITE GASKET SHEETS AND GASKETS

The product range of Planigraph® graphite gasket sheets and gaskets consists of 4 product families, available both in the Industrial Grade version and the Grade Plus version with certifications.

Main features

The maximum “gasket pressure” applicable to Planigraph® depends on the model, its thickness and the width of the gasket (area). If Planigraph gaskets on RF flanges® are usable up to the 300/600 lbs class, with the increase in sealing surface they can be used up to a pressure of 200÷230 N/mm² (style LGRHDI). Planigraph® graphite is easy to install and adaptable to the surface of flanges.

It is unaffected by thermal cycles and does not age, maintaining elastic and sealing properties for a long time.

Graphite is not suitable with oxidising fluids and can be used in the T range of -200/550°C.

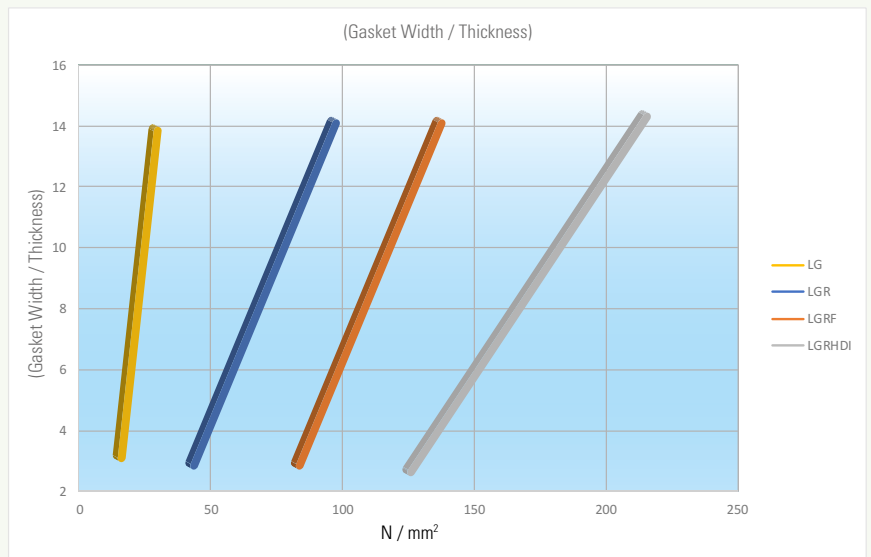
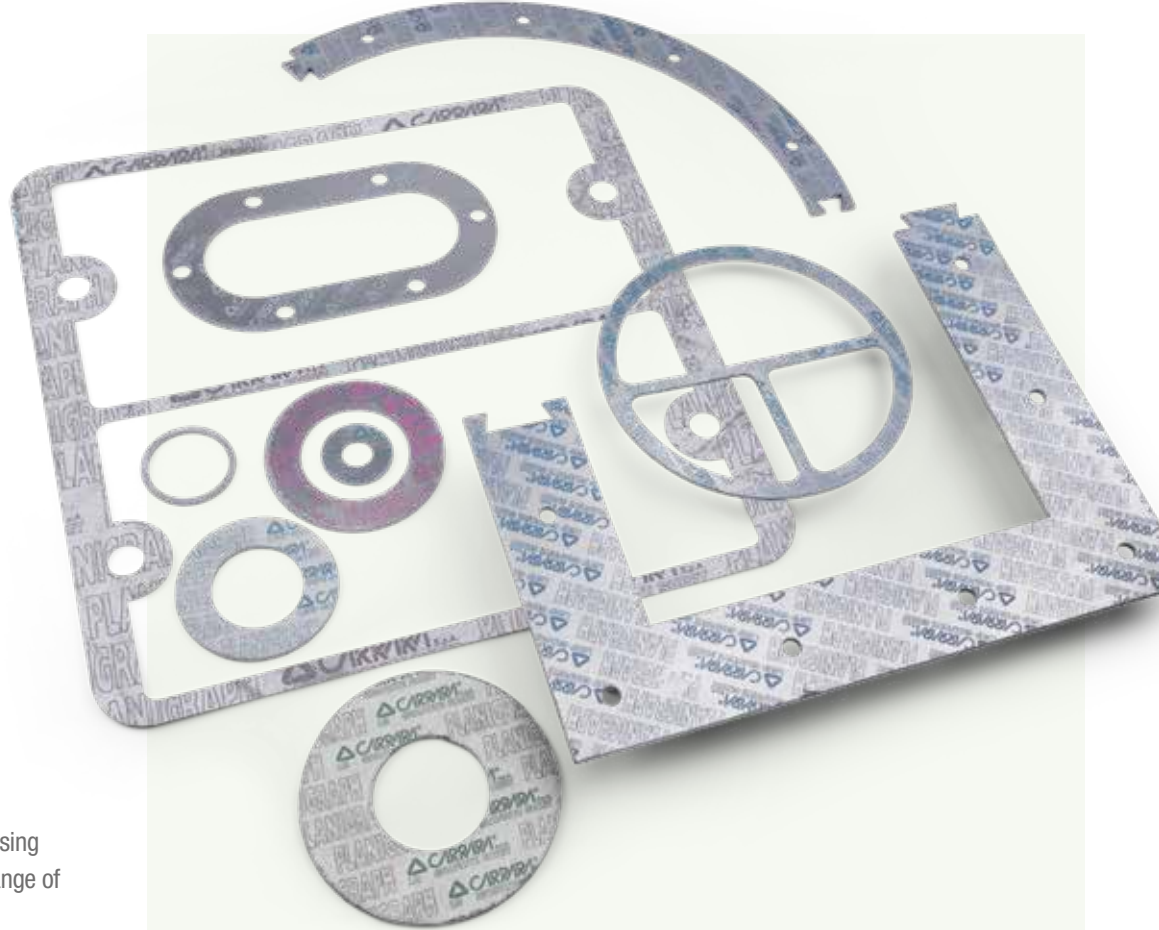

PLANIGRAPH® LGRF

Graphite gasket sheets and gaskets with multiple perforated metal inserts.

Planigraph® LGRF gaskets are made of expanded graphite supported by a 0.10 mm perforated sheet in 316L grade stainless steel.

LGRF has a compressibility of 40% and an elastic recovery between 15 and 20%, with a maximum assembly stress in service of 140 N/mm².

The residual stress after 16 hours at 300°C is greater than 45 N/mm². Planigraph® LGRF gasket sheets are available with double reinforced laminate in the LGRF2 version.



LGRF

Graphite density	g/cm ³	1.0
Carbon content	%	> 98.0
Ash content	%	< 2.0
Reinforcing steel foil details		
Material	-	SS316L
Form	-	tanged
Thickness	mm	0.10
Number	--	1
Compressibility	%	30--40
Recovery	%	15--20
Stress	N/mm ²	> 45
Temperature	°C	- 200/+550
Maximum assembly load under service condition	N/mm ²	140

Sizes available

Thicknesses (tolerance +/- 10%)

(mm) 1,0 ÷ 1,5 ÷ 2,0 ÷ 3,0

(inch) 3/64" ÷ 1/16" ÷ 5/64" ÷ 1/8"

Formats (tolerance +/- 5%)

(mm) 1.000 x 1.000 ÷ 1.500 x 1.500

(inch) 40" x 40" ÷ 60" x 60"

■ PLANIGRAPH® LGRHDI

Graphite gasket sheets and gaskets with multiple smooth metal inserts.

Planigraph® LGRHDI gaskets are specific for high pressure applications. Expanded graphite is supported by multiple 0.05mm laminates in 316L grade stainless steel. LGRHDI has a compressibility of 25- 30% and an elastic recovery between 15 and 20%, with a maximum assembly stress in service of 200 N/ mm².

The residual stress after 16 hours at 300°C is greater than 45 N/mm².



Sizes available

Thicknesses (tolerance +/- 10%)
 (mm) 1,0 ÷ 1,5 ÷ 2,0 ÷ 3,0
 (inch) 3/64" ÷ 1/16" ÷ 5/64" ÷ 1/8"

Formats (tolerance +/- 5%)
 (mm) 1.000 x 1.000 ÷ 1.500 x 1.500
 (inch) 40" x 40" ÷ 60" x 60"

LGRHDI

Graphite density	g/cm ³	1.0
Carbon content	%	> 98.0
Ash content	%	< 2.0
Reinforcing steel foil details		
Material	-	SS316L
Form	-	smooth
Thickness	mm	0.05
Number	- -	*
Compressibility	%	25--35
Recovery	%	> 15
Stress	N/mm ²	> 45
Temperature	°C	-200/+550
Maximum assembly load under service condition	N/mm ²	140

* il numero delle lamine di rinforzo dipende dallo spessore del foglio

PLANIGRAPH® LGR

Graphite gasket sheets and gaskets with smooth metal insert.

Planigraph® LGR gaskets are specific for applications up to PN40 (600 lbs) for RF, LMF and LTG flanges of pipelines, valves and heat exchangers. Graphite is supported by a smooth SS316L grade stainless steel insert. Excellent compressibility up to 50% and good recovery between 10 and 15%.



PLANIGRAPH® LG

Graphite gasket sheets and gaskets without metal insert.

Planigraph® LG gaskets are intended for special low pressure or vacuum applications. Graphite is not supported by any insert, therefore particular care is required when cutting and installing the gasket.



Sizes available

Thicknesses (tolerance +/- 10%)
 (mm) 0,5 ÷ 1,0 ÷ 1,5 ÷ 2,0 ÷ 3,0
 (inch) 1/64" ÷ 3/64" ÷ 1/16" ÷ 5/64" ÷ 1/8"

Formats (tolerance +/- 5%)
 (mm) 1.000 x 1.000 ÷ 1.500 x 1.500
 (inch) 40" x 40" ÷ 60" x 60"



		LG	LGR
Graphite density	g/cm ³	1.0	1.0
Carbon content	%	> 98.0	> 98.0
Ash content	%	< 2.0	< 2.0
Reinforcing steel foil details	Material	-	SS316L
	Form	-	smooth
	Thickness	mm	-- 0.05
	Number	--	-- 1
Compressibility	%	40-50	40--50
Recovery	%	10-15	10--15
Stress	N/mm ²	> 47	> 45
Temperature	°C	-200/+550	-200/+550
Maximum assembly load under service condition	N/mm ²	40	60

2.0 PLANIFLON® - PTFE

PLANIFLON® - PTFE



PLANIFLON® B13

Planiflon® B13 is a modified PTFE, silica filled, bi-directionally oriented that minimises the effects of relaxation and viscous flow typical of these gaskets, ensuring great reliability even in the most challenging applications.

Planiflon® B13 is applicable on RF flanges up to 600 psi class while on other flanges up to 80 bar. Chemical compatibility extends across the whole range 0 ÷ 14 with the exception of fluids for which siliceous filler is not compatible.



Sizes available

Thicknesses (tolerance +/- 10%)
 (mm) 0,75 ÷ 1,00 ÷ 1,50 ÷ 2,00
 2,50 ÷ 3,00 ÷ 4,00 ÷ 5,00 ÷ 6,00
 (inch) 1/32" ÷ 3/64" ÷ 1/16" ÷ 5/64"
 3/32" ÷ 1/8" ÷ 5/32" ÷ 3/16" ÷ 1/4"

Formats (tolerance +/- 5%)
 (mm) 1.500 x 1.500
 (inch) 60" x 60"

Certifications

- TA LUFT VDI 2440
- BAM Oxygen Service

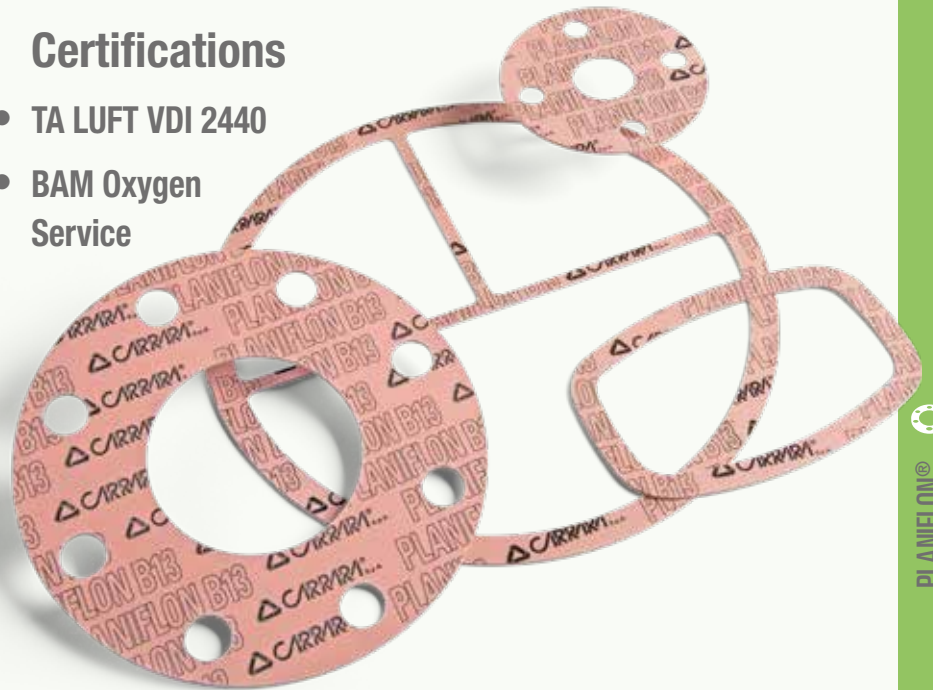

B13

Color	Pink	
Composition	Modified PTFE silica filler	
Density	g/cm ³	2.2
Operative temperature range	°C	-260/+260
Max operating pressure	Bar	80
P x T max	Bar x °C	
thickness 0,5 ÷ 2,0 mm		12000
thickness 3,0 mm		8500
Leakage	mg* s ⁻¹ *m ⁻¹	< 0.05
Creep Relaxation	%	< 24
Compression range	%	> 4
Recovery DIN 3535-6	%	> 1,7
pH range	-	0-14

PLANIFLON® B14

Planiflon® B14 gaskets are loaded with hollow glass microsphere in order to give the product greater flexibility, a requirement that is essential in many applications where a low torque value is needed. Thanks to the bi-axially modified PTFE, creep is moderate and this allows the use of the product in situations characterised by frequent thermal cycles.

Planiflon® B14 is the recommended gasket for LNG Carriers.



Sizes available

Thicknesses (tolerance +/- 10%)
 (mm) 0,75 ÷ 1,00 ÷ 1,50 ÷ 2,00
 2,50 ÷ 3,00 ÷ 4,00 ÷ 5,00 ÷ 6,00
 (inch) 1/32" ÷ 3/64" ÷ 1/16" ÷ 5/64"
 3/32" ÷ 1/8" ÷ 5/32" ÷ 3/16" ÷ 1/4"

Formats (tolerance +/- 5%)
 (mm) 1.500 x 1.500
 (inch) 60" x 60"



Main features

- Excellent torque value retention
- It can be used with a wide range of products and in many applications
- It does not burn
- It does not feed bacterial growth

B14

Color	Light Blue	
Composition	Modified PTFE Hollow Glass Microsphere	
Density	g/cm ³	1.4
Operative temperature range	°C	-260/+260
Max operating pressure	Bar	50
P x T max	Bar x °C	
	thickness 0,5 ÷ 2,0 mm	12000
	thickness 3,0 mm	8500
Leakage	mg* s ⁻¹ *m ⁻¹	< 0.05
Creep Relaxation	%	< 19
Compression range	%	> 32
Recovery DIN 3535-6	%	> 7
pH range	-	0-14

PLANIFLON® B15

Planiflon® B15 is a modified PTFE loaded with Barium Sulphate for all those applications where silica fillers are not suitable. Planiflon® B15 gaskets can be installed both on line flanges and on those of heat exchangers and valve pumps, always guaranteeing an effective and safe seal.



Main features

- High sealing performance
- Low emissions
- Moderate creep

B15

Color	Off white	
Composition	Modified PTFE with Barium Sulphate filler	
Density	g/cm ³	2.8
Operative temperature range	°C	-260/+260
Max operating pressure	Bar	80
P x T max	Bar x °C	
		thickness 0,5 ÷ 2,0 mm
	thickness 3,0 mm	8500
Leakage	mg* s ⁻¹ *m ⁻¹	< 0.005
Creep Relaxation	%	< 28
Compression range	%	> 4.3
Recovery DIN 3535-6	%	> 2.1
pH range	-	0-14

Sizes available

Thicknesses (tolerance +/- 10%)
 (mm) 0,75 ÷ 1,00 ÷ 1,50 ÷ 2,00
 2,50 ÷ 3,00 ÷ 4,00 ÷ 5,00 ÷ 6,00
 (inch) 1/32" ÷ 3/64" ÷ 1/16" ÷ 5/64"
 3/32" ÷ 1/8" ÷ 5/32" ÷ 3/16" ÷ 1/4"

Formats (tolerance +/- 5%)
 (mm) 1.500 x 1.500
 (inch) 60" x 60"

■ PLANIFLON® E12 EXPANDED PTFE GASKET SHEETS AND GASKETS

Planiflon® E12 is inert, non-toxic and easy to install.

Planiflon® E12 is a universal gasket that can be used with all types of flanges and almost all types of fluid. Planiflon® E12 is inert, non-toxic and easy to install thanks to its ability to easily adapt it self to sealing surfaces and compensates for any defects.

Planiflon® E12 is a multidirectional expanded PTFE gasket with very high mechanical resistance, low creep value and excellent ability to operate in a wide temperature range.



Sizes available

Thicknesses (tolerance +/- 10%)
(mm) 0,75 ÷ 1,00 ÷ 1,50 ÷ 2,00
2,50 ÷ 3,00 ÷ 4,00 ÷ 5,00 ÷ 6,00
(inch) 1/32" ÷ 3/64" ÷ 1/16" ÷ 5/64"
3/32" ÷ 1/8" ÷ 5/32" ÷ 3/16" ÷ 1/4"

Formats (tolerance +/- 5%)
(mm) 1.500 x 1.500
(inch) 60" x 60"

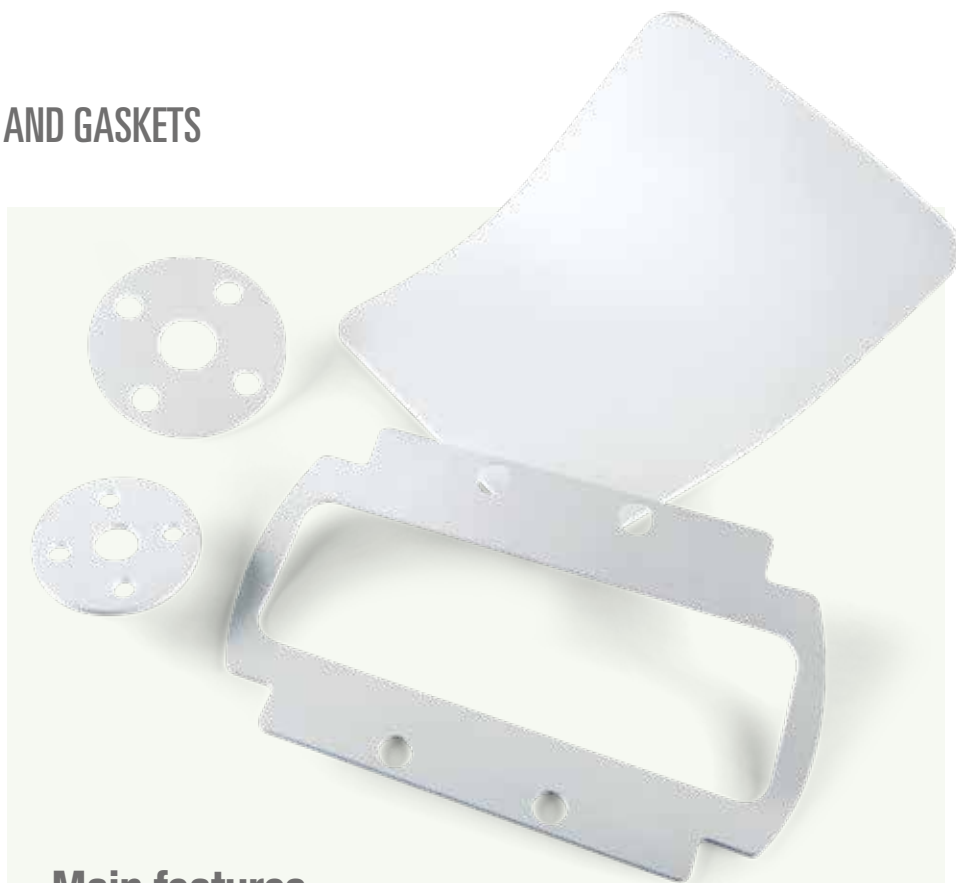

Main features

- High sealing performance
- Low emissions
- Moderate creep

E12

Color	White	
Composition	Expanded PTFE	
Density	g/cm ³	0.9
Operative temperature range	°C	-200/+260
Max operating pressure	Bar	50
P x T max	Bar x °C	
	thickness 0,5 ÷ 2,0 mm	5000
	thickness 3,0 mm	3500
Leakage	mg* s ⁻¹ *m ⁻¹	< 0.005
Creep Relaxation	%	38
Compression range	%	45
Recovery	%	14
pH range	-	0-14

■ PLANIFLON® SEALTAPE

Planiflon® Sealtape is a gasket in pure monodirectional expanded PTFE, usable across the entire pH range, with limitations for elemental fluorine or alkali metals at high temperatures and pressures.

Thanks to its particular structure, it is suitable for applications in chemical, pharmaceutical and food industries.

It is particularly suitable for applications with modest torque values (e.g. flanges in graphite, glass, etc.) thanks to the particularly positive deformation curve.



Planiflon® Sealtape has high plastic deformability with modest cold flow and can be used to create sealing in a short time on any surface, also closely adhering with low torque values and in presence of irregular or damaged surfaces.

Planiflon® Sealtape is non-toxic and does not contaminate the products it comes into contact with as it doesn't release material substances or particles.



T° C -200 / +260		pH 0- 14	
SIZE			
type	Width mm	Thickness mm	Spool Length m
P_ST_03	3	1,5	30
P_ST_05	5	2	20
P_ST_07	7	2,5	15
P_ST_10	10	3	10
P_ST_12	12	4	10
P_ST_14	14	5	5/25
P_ST_17	17	6	5/25
P_ST_20	20	7	5/25
P_ST_25	25	8	5

PLANIFLEX®

CSF COMPRESSED FIBRES



■ PLANIFLEX® PF64 RESISTANT AND RELIABLE

Planiflex® PF64 is a gasket made of aramid fibres and NBR based materials specially selected to meet high performance standards for a wide range of industrial applications.

Planiflex® PF64 can be applied continuously in the temperature range -40°C to 250°C and in the pressure ranges up to 600 lbs and PN40 ratings. These gaskets display chemical compatibility in the pH range typical of that of nitrile rubbers.

Planiflex® PF64 is applicable for sealing with vapours, lubricants, solvents, gases, steam and many diluted acids and alkali. It can be used as a gasket for PTFE bags.



Planiflex® PF64 can be used for a wide range of industrial applications, it is easy to handle, install and remove. Planiflex® PF64 displays excellent stress retention properties and excellent sealing performance.



PF64

Color	Blue		
Binder	NBR		
Density ± 5%	g/cm ³	1.9	
Tensile strength DIN 52910	MPa	8	
Compressibility ASTM F36	%	11	
Recovery ASTM F36	%	50	
Residual stress DIN 52913	16 hours, 300°C, 50 N/mm ²	MPa	22
	16 hours, 175°C, 50 N/mm ²	MPa	28
Thickness increase ASTM F146	1) Oil IRM 903, 5h, 150°C	%	5
	2) ASTM Fuel B, 5h, 23°C	%	5
	3) Distilled water, 5h, 100°C	%	2
Max Operating conditions	Peak Temp.	°C	350
	Continuous Temp.	°C	280
	Continuous Temp. with steam	°C	220
Pressure	MPa	10	

Sizes available

Thicknesses (tolerance +/- 10%)

(mm) 0,50 ÷ 0,80 ÷ 1,00 ÷ 1,50 ÷ 2,00 ÷ 2,50 ÷ 3,00 ÷ 4,00 ÷ 5,00
(inch) 1/64" ÷ 1/32" ÷ 3/64" ÷ 1/16" ÷ 5/64" ÷ 3/32" ÷ 1/8" ÷ 5/32" ÷ 3/16"

Formats (tolerance +/- 5%)

(mm) 1.500 x 1.500 ÷ 1.500 x 3.000
(inch) 60" x 60" ÷ 60" x 120"

■ PLANIFLEX® PF SAFE AND EFFECTIVE

■ PLANIFLEX® PF65

Thanks to the special materials that form its structure, **Planiflex® PF65** guarantees sealing with a wide set of fluids including steam, water, fuels, lubricating oils, saline solutions, weakly acidic and basic solutions, demonstrating excellent resistance to ageing.



Planiflex® PF65 can be used at continuous temperatures up to 340° C and up to 250° C in the presence of steam.

The residual stress at 175°C is 24MPa and it guarantees gasket's ability to keep sealing efficient for long service cycles even at high temperatures.

The typical field of use of **Planiflex® PF65** on RF flanges is up to pressure ratings of 600lbs and PN40.



PF65

Color		Blue
Binder		NBR
Density ± 5%	g/cm ³	1.9
Tensile strenght DIN 52910	MPa	9.0
Compressibility ASTM F36	%	10
Recovery ASTM F36	%	55
Residual stress DIN 52913		
16 hours, 300°C, 50 N/mm ²	MPa	29
16 hours, 175°C, 50 N/mm ²	MPa	34
Thickness increase ASTM F146		
1) Oil IRM 903, 5h, 150°C	%	6
2) ASTM Fuel B, 5h, 23°C	%	6
3) Distilled water, 5h, 100°C	%	2
Max Operating conditions		
Peak Temp.	°C	400
Continuous Temp.	°C	340
Continuous Temp. with steam	°C	250
Pressure	MPa	12

Sizes available

Thicknesses (tolerance +/- 10%)

(mm) 0,50 ÷ 0,80 ÷ 1,00 ÷ 1,50 ÷ 2,00 ÷ 2,50 ÷ 3,00 ÷ 4,00 ÷ 5,00
 (inch) 1/64" ÷ 1/32" ÷ 3/64" ÷ 1/16" ÷ 5/64" ÷ 3/32" ÷ 1/8" ÷ 5/32" ÷ 3/16"

Formats (tolerance +/- 5%)

(mm) 1.500 x 1.500 ÷ 1.500 x 3.000
 (inch) 60" x 60" ÷ 60" x 120"

PLANIFLEX® PF81

Planiflex™ PF81 is made of aramidic fibres, graphite and nitrile binder that guarantees reliability and safety.

PLANIFLEX® PF13

Planiflex® PF13 is a compressed fibre sheet with CSM binder for gaskets intended for use with products of chemical industry.

PLANIFLEX® PF63

Planiflex® PF63 is made of aramid fibres and nitrile binder for general uses.

PLANIFLEX® PF41

Planiflex® PF41 is made of organic fibres and nitrile binder, it is the universal gasket for countless fields of application.



PF81 PF13 PF63 PF41

		Black	Beige	Blue	green
Color		Black	Beige	Blue	green
Binder		NBR	CSM	NBR	NBR
Density ± 5%	g/cm ³	1.9	1.9	1.9	1.9
Tensile strenght DIN 52910	MPa	8	9	6	8
Compressibility ASTM F36	%	11	9	11	9
Recovery ASTM F36	%	50	50	50	60
Residual stress DIN 52913					
16 hours, 300°C, 50 N/mm ²	MPa	22			
16 hours, 175°C, 50 N/mm ²	MPa	28	25	25	20
Thickness increase ASTM F146					
1) Oil IRM 903, 5h, 150°C	%	5		12	10
2) ASTM Fuel B, 5h, 23°C	%	5			10
3) Distilled water, 5h, 100°C	%	2			
4) 40% HNO ₃ 23oC/18h	%		8		
5) 65% H ₂ SO ₄ 23oC/48h	%		10		
Max Operating conditions					
Peak Temp.	°C	350	200	250	180
Continuous Temp.	°C	280	150	180	140
Continuous Temp. with steam	°C	220		150	120
Pressure	MPa	10	4	5	4

Sizes available

Thicknesses (tolerance +/- 10%)

(mm) 0,50 ÷ 0,80 ÷ 1,00 ÷ 1,50 ÷ 2,00 ÷ 2,50 ÷ 3,00 ÷ 4,00 ÷ 5,00

(inch) 1/64" ÷ 1/32" ÷ 3/64" ÷ 1/16" ÷ 5/64" ÷ 3/32" ÷ 1/8" ÷ 5/32" ÷ 3/16"

Formats (tolerance +/- 5%)

(mm) 1.500 x 1.500 ÷ 1.500 x 3.000

(inch) 60" x 60" ÷ 60" x 120"

PLANIX®
MEGATHERM

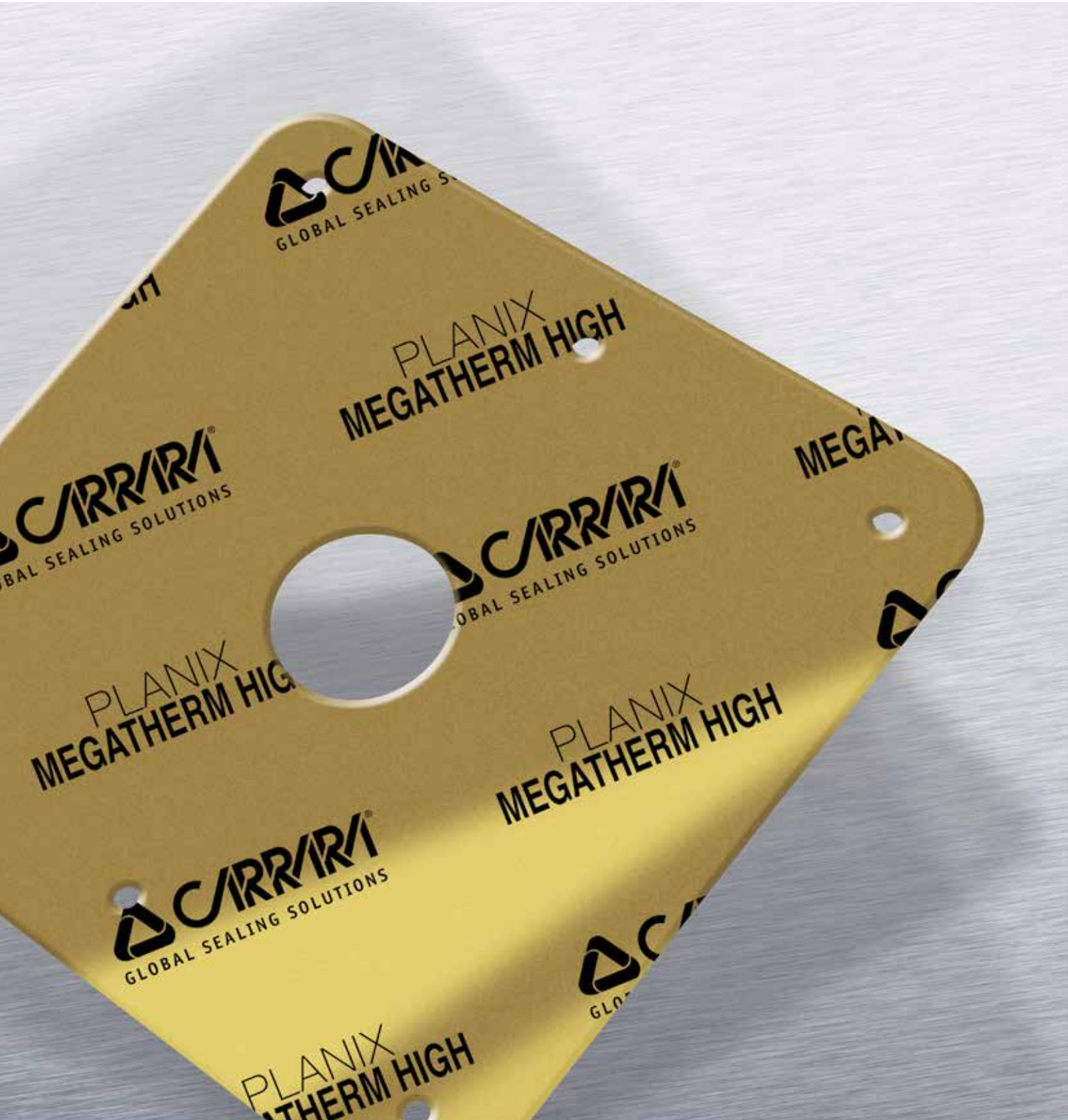

PLANIX®

Planix® MEGATHERM it is a gasket sheet made with materials based on mica and binders deposited on a stainless steel support for sealing in a wide range of industrial applications where other gaskets can not be used.



Temperature

Planix® MEGATHERM is applicable up to 900°C with peak limit up to 1000°C.

Pressure range

Planix® MEGATHERM is safely applicable at low pressures in the ratings of 150 lbs and PN16.

pH range

Planix® MEGATHERM is applicable in a wider range than that of graphite. In fact, mica is almost unaffected by both acids and strong bases, meaning it can be used in contact with almost all fluids and gases.



Planix® MEGATHERM, safe and durable in most testing conditions.

Planix® MEGATHERM can be used with molten salts and oxidising gases at high temperatures without fear of excessive weight losses due to oxidation and combustion, preserving the sealing for a long time even in the presence of frequent thermal cycles.

Material	Flexible Mica	
Insert	SS316 tanged thickness 0,1 mm	
Max operating Temperature	°C	900
Peak Temperature for short time	°C	1.000
Max operating pressure	bar	20
Leakage DIN 3535-6	mg*s-1*m-1	< 0,1
Stress retention DIN 52913	N/mm ²	40
Creep Relaxation DIN3535-6	%	< 18
Compressibility ASTM F36	%	> 20
Recovery ASTM F36	%	> 2,2

Sizes available

Thicknesses (tolerance +/- 10%)

(mm) 1,00 ÷ 2,00 ÷ 3,00

(inch) 3/64" ÷ 5/64" ÷ 1/8"

Formats (tolerance +/- 5%)

(mm) 1.000 x 1.000 ÷ 1.500 x 1.500

(inch) 40" x 40" ÷ 60" x 60"

PLANIX® RUBBER GASKET SHEETS AND GASKETS

Planix® Rubber Gasketing Sheets is the range of rolls and sheets for rubber gaskets belonging to the Carrara product range and it includes:

- NR Natural Rubber
- EPDM Ethylene-Propylene Diene Monomer Rubber
- SB Styrene Butadiene Rubber
- CSM Chlorosulfonated-Polyethylene Rubber
- CR Polychloroprene Rubber
- SR Silicone Rubber
- FKM Fluorocarbon Rubber

Material selection

When selecting elastomeric gaskets, consideration must be given to:

- The primary fluids with which the gasket will be in contact (primary chemical compatibility).
- The secondary fluids (lubricants or others) to which the gasket will be exposed (secondary chemical compatibility).
- The suitability of the materials at the extremes application temperatures, hot and cold.
- The presence of external contaminants such as abrasives.

The chemical interference of primary and secondary fluids must undergo careful analysis. To ensure an appropriate life expectancy, excessive deterioration must be avoided by checking that, among other things, the conditions of:

- significant volume variation
- significant hardness increase or decrease in
- significant tensile variation strength.



Material	UM	PLANIX 11 Natural Rubber
Color	--	Black
Specific Gravity	g/cm ³	0,97 ± 0,03
Thickness	mm	1,0 to 50,0
Width	m	1,2
Lenght	m	1,2 to 10,0
Hardness	Shore A	40 ± 5
Operating Temperature	°C	-35 ÷ 70
Tensile Strength	MPa	20,0
Elongation	%	550
Tear Resistance	N/mm	40
Compression Set (22 hrs at 70°C)	%	40

Thickness tolerance +/- 10%

Format tolerance +/- 5%



PLANIX 03 EPDM Rubber	PLANIX 05 White SBR Rubber	PLANIX 15 Red SBR Rubber	PLANIX 07 CSM Rubber	PLANIX 08 NBR Rubber	PLANIX 09 Polychloroprene Rubber	PLANIX 17 Silicone Rubber	PLANIX 19 FKM Rubber
Black	White	Black	Black	Black	Black	Red	Black
1,25 ± 0,05	1,5 ± 0,05	1,5 ± 0,03	1,4 ± 0,03	1,24 ± 0,03	1,5 ± 0,03	1,25 ± 0,03	1,5 ± 0,03
1,0 to 50,0	1,0 to 50,0	1,0 to 50,0	1,0 to 50,0	1,0 to 50,0	1,0 to 50,0	1,0 to 50,0	1,0 to 50,0
1,2	1,2	1,2	1,2	1,2	1,2	1,0	1,2
1,2 to 10,0	1,2 to 10,0	1,2 to 10,0	1,2 to 10,0	1,2 to 10,0	1,2 to 10,0	1,0	1,2 to 10,0
60 ± 5	60 ± 5	70 ± 5	70 ± 5	70 ± 5	60 ± 5	60 ± 5	70 ± 5
-25 ÷ 120	-25 ÷ 120	-25 ÷ 70	-35 ÷ 140	-25 ÷ 120	-20 ÷ 100	-70 ÷ 200	-30 ÷ 250
4,0	8,0	4,0	7,0	14,0	4,5	7,0	7,5
200	400	200	400	300	250	300	250
10	15	14	17	55	12	20	18
40	40	40	40	20	35	34	62



PLANIGRAPH®

GRAPHITE GASKET SHEETS



LG

PLANIGRAPH® LG

Planigraph® LG gaskets are designed for special low pressure or vacuum applications.

Graphite density	g/cm ³	1,0
Carbon content	%	> 98,0
Ash content	%	< 2,0
Reinforcing steel foil details		
Material	-	-
Form	-	-
Thickness	mm	--
Number	--	--
Compressibility	%	40-50
Recovery	%	10-15
Stress	N/mm ²	> 47
Temperature	°C	- 200/+550
Maximum assembly load under service condition	N/mm ²	40



LGR

PLANIGRAPH® LGR

Planigraph® LGR gaskets are made of expanded graphite supported by a 0.05 mm s316L grade stainless steel laminate.

Graphite density	g/cm ³	1,0
Carbon content	%	> 98,0
Ash content	%	< 2,0
Reinforcing steel foil details		
Material	-	SS316L
Form	-	smooth
Thickness	mm	0,05
Number	--	1
Compressibility	%	40-50
Recovery	%	10-15
Stress	N/mm ²	> 45
Temperature	°C	- 200/+550
Maximum assembly load under service condition	N/mm ²	60



LGRF

PLANIGRAPH® LGRF

Planigraph® LGRF gaskets are made of expanded graphite supported by a 0.10 mm perforated 316L grade stainless steel laminate.

Graphite density	g/cm ³	1,0
Carbon content	%	> 98,0
Ash content	%	< 2,0
Reinforcing steel foil details		
Material	-	SS316L
Form	-	tanged
Thickness	mm	0,10
Number	--	1
Compressibility	%	30-40
Recovery	%	15-20
Stress	N/mm ²	> 45
Temperature	°C	- 200/+550
Maximum assembly load under service condition	N/mm ²	140



LGRF2

PLANIGRAPH® LGRF2

Planigraph® LGRF2 gaskets are made of expanded graphite supported by two 0.10 mm perforated 316L grade stainless steel laminates.

Graphite density	g/cm ³	1,0
Carbon content	%	> 98,0
Ash content	%	< 2,0
Reinforcing steel foil details		
Material	-	SS316L
Form	-	smooth
Thickness	mm	0,10
Number	--	2
Compressibility	%	30-40
Recovery	%	20
Stress	N/mm ²	> 45
Temperature	°C	- 200/+550
Maximum assembly load under service condition	N/mm ²	140



LGRHDI

PLANIGRAPH® LGRHDI

Planigraph® LGRHDI gaskets are made of multiple 0.05mm 316L grade stainless steel laminates for high pressure applications.

Graphite density	g/cm ³	1,0
Carbon content	%	> 98,0
Ash content	%	< 2,0
Reinforcing steel foil details		
Material	-	SS316L
Form	-	smooth
Thickness	mm	0,10
Number	--	*
Compressibility	%	40-50
Recovery	%	10-15
Stress	N/mm ²	> 47
Temperature	°C	- 200/+550
Maximum assembly load under service condition	N/mm ²	40

Sizes available

Thicknesses (tolerance +/- 10%)
 (mm) 0,80 - 1,00 - 1,50 - 2,00 - 3,00
 (inch) 1/32" ÷ 3/64" ÷ 1/16" ÷ 5/64" ÷ 1/8"

Formats (tolerance +/- 5%)
 (mm) 1000 x 1000 e 1500 x 1500
 (inch) 40" x 40" ÷ 60" x 60"

Contact Carrara's technical office for information on gasket torque factors.

We assume no responsibility for errors due to wrong selection and inappropriate use of the material.

WARNING: The data shown in the tables refer to a typical behaviour of the materials and are the result of laboratory and factory tests carried out over the years. The specifications shown can change without notification. Wrong selection of the material for the specific application or improper use can cause damage to property and people. We assume no responsibility for errors due to wrong selection and inappropriate use of the material.

Typical values for 1.50 mm thickness

* The number of reinforcement layers depends on the thickness.

PLANIFLON® PTFE GASKET SHEETS



B13

PLANIFLON® B13

Planiflon® B13 gaskets are applicable on RF flanges up to 600 psi class.

Color	Pink	
Composition	Modified PTFE silica filler	
Density	g/cm ³	2.2
Operative temperature range	°C	-260/+260
Max operating pressure	Bar	80
P x T max	Bar x °C	
thickness 0,5 ÷ 2,0 mm	12000	
thickness 3,0 mm	8500	
Leakage	mg* s ⁻¹ *m ⁻¹	<0.05
Creep Relaxation	%	24
Compression range	%	> 4
Recovery	%	< 1.7
pH range	-	0-14



B14

PLANIFLON® B14

Planiflon® B14 gaskets are loaded with glass microspheres for lower density and greater flexibility.

Color	Light Blue	
Composition	Modified PTFE Hollow Glass Microsphere	
Density	g/cm ³	1.4
Operative temperature range	°C	-260/+260
Max operating pressure	Bar	50
P x T max	Bar x °C	
thickness 0,5 ÷ 2,0 mm	12000	
thickness 3,0 mm	8500	
Leakage	mg* s ⁻¹ *m ⁻¹	< 0.05
Creep Relaxation	%	< 19
Compression range	%	> 32
Recovery	%	< 7
pH range	-	0-14



B15

PLANIFLON® B15

Planiflon® B15 gaskets are made of modified PTFE filled with Barium Sulphate.

Color	Off white	
Composition	Modified PTFE with Barium Sulphate filler	
Density	g/cm ³	2.8
Operative temperature range	°C	-260/+260
Max operating pressure	Bar	80
P x T max	Bar x °C	
thickness 0,5 ÷ 2,0 mm	12000	
thickness 3,0 mm	8500	
Leakage	mg* s ⁻¹ *m ⁻¹	<0.005
Creep Relaxation	%	< 23
Compression range	%	> 4.3
Recovery	%	< 2.1
pH range	-	0-14



E12

PLANIFLON® E12

Planiflon® E12 gaskets are made of expanded PTFE and it can be used with almost all types of fluid.

Color	White	
Composition	Expanded PTFE	
Density	g/cm ³	0.9
Operative temperature range	°C	-200/+260
Max operating pressure	Bar	50
P x T max	Bar x °C	
thickness 0,5 ÷ 2,0 mm	5000	
thickness 3,0 mm	3500	
Leakage	mg* s ⁻¹ *m ⁻¹	< 0.005
Creep Relaxation	%	38
Compression range	%	45
Recovery	%	14
pH range	-	0-14

Thicknesses (tolerance +/- 10%)*
(mm) da 0,80 fino a 6,00
(inch) da 1/32" a 1/4"



B01 / B02

PLANIFLON® B01/B02

Planiflon® B01 e B02 gaskets are respectively in Virgin PTFE and glass filled PTFE.

Color	White	
Composition	V PTFE/ V PTFE glass	
Density	g/cm ³	2.1/ 2.2
Operative temperature range	°C	-200/+260
Max operating pressure	Bar	50
P x T max	Bar x °C	
thickness 0,5 ÷ 2,0 mm	5000	
thickness 3,0 mm	3500	
Leakage	mg* s ⁻¹ *m ⁻¹	< 0.05
Tensile break strength	%	> 24 / > 11
Compression range	%	14-17 / 7-10
Recovery	%	20 / 25
pH range	-	0-14

Formats (tolerance +/- 5%)*
(mm) da 600 x 600 a 1.500 x 1.500
(inch) da 25" x 25" a 60" x 60"



B05

PLANIFLON® B05

Planiflon® B05 gaskets are in graphite filled PTFE for gaskets and sealing rings.

Color	Black	
Composition	V PTFE graphite filled	
Density	g/cm ³	2.1
Operative temperature range	°C	-200/+260
Max operating pressure	Bar	50
P x T max	Bar x °C	
thickness 0,5 ÷ 2,0 mm	5000	
thickness 3,0 mm	3500	
Leakage	mg* s ⁻¹ *m ⁻¹	< 0.05
Tensile break strength	%	> 14
Compression range	%	5 - 6
Recovery	%	22
pH range	-	0-14

* Thickness availability is linked to the type of material
Contact Carrara's technical office for information on gasket torque factors. We assume no responsibility for errors due to wrong selection and inappropriate use of the material.

PLANIFLEX®

COMPRESSED SHEETS - CSF



PF64

PLANIFLEX® PF64

Planiflex® PF64 gaskets are made of aramid fibres and NBR based materials.

Color	Blue	
Binder	NBR	
Density	g/cm ³	1,9
Tensile strength DIN 52910	N/mm ²	8
Compressibility ASTM F36	%	11
Recovery ASTM F36	%	50
Residual stress DIN 52913:		
16 hours, 300°C, 50 N/mm ²	MPa	22
16 hours, 175°C, 50 N/mm ²	MPa	28
Thickness increase ASTM F146:		
1) Oil IRM 903, 5h, 150°C	%	5
2) ASTM Fuel B, 5h, 23°C	%	5
3) Distilled water, 5h, 100°C	%	2
Max Operating conditions:		
Peak Temperature	°C	350
Continuous Temperature	°C	280
Continuous Temperature with Steam	°C	220
Pressure	MPa	10



PF65

PLANIFLEX® PF65

Planiflex® PF65 can be used up to a continuous temperature of 250°C with steam.

Color	Blue	
Binder	NBR	
Density	g/cm ³	1,9
Tensile strength DIN 52910	N/mm ²	9,0
Compressibility ASTM F36	%	10
Recovery ASTM F36	%	55
Residual stress DIN 52913:		
16 hours, 300°C, 50 N/mm ²	MPa	29
16 hours, 175°C, 50 N/mm ²	MPa	34
Thickness increase ASTM F146:		
1) Oil IRM 903, 5h, 150°C	%	6
2) ASTM Fuel B, 5h, 23°C	%	6
3) Distilled water, 5h, 100°C	%	2
Max Operating conditions:		
Peak Temperature	°C	400
Continuous Temperature	°C	340
Continuous Temperature with Steam	°C	250
Pressure	MPa	12



PF81F

PLANIFLEX® PF81F

Planiflex® PF81F is a gasket sheet made of a special combination of heat-resistant fibres.

Color	Black	
Binder	NBR	
Density	g/cm ³	1,9
Tensile strength DIN 52910	N/mm ²	9,0
Compressibility ASTM F36	%	10
Recovery ASTM F36	%	50
Residual stress DIN 52913:		
16 hours, 300°C, 50 N/mm ²	MPa	25
16 hours, 175°C, 50 N/mm ²	MPa	30
Thickness increase ASTM F146:		
1) Oil IRM 903, 5h, 150°C	%	5
2) ASTM Fuel B, 5h, 23°C	%	6
3) Distilled water, 5h, 100°C	%	2
Max Operating conditions:		
Peak Temperature	°C	400
Continuous Temperature	°C	320
Continuous Temperature with Steam	°C	250
Pressure	MPa	8



PF13

PLANIFLEX® PF13

Planiflex® PF13 is the sheet of compressed fibres with CSM binder for gaskets suitable for the chemical industry.

Color	Beige	
Binder	NBR	
Density	g/cm ³	1,9
Tensile strength DIN 52910	N/mm ²	9
Compressibility ASTM F36	%	9
Recovery ASTM F36	%	50
Residual stress DIN 52913:		
16 hours, 300°C, 50 N/mm ²	MPa	25
16 hours, 175°C, 50 N/mm ²	MPa	25
Thickness increase ASTM F146:		
1) Oil IRM 903, 5h, 150°C	%	8
2) ASTM Fuel B, 5h, 23°C	%	10
3) Distilled water, 5h, 100°C	%	
Max Operating conditions:		200
Peak Temperature	°C	150
Continuous Temperature	°C	
Continuous Temperature with Steam	°C	4
Pressure	MPa	12



PF81

PLANIFLEX® PF81

Planiflex® PF81 is made of aramid fibres, graphite and NBR binder to ensure maximum reliability.

Color	Black	
Binder	NBR	
Density	g/cm ³	1,9
Tensile strength DIN 52910	N/mm ²	8
Compressibility ASTM F36	%	11
Recovery ASTM F36	%	50
Residual stress DIN 52913:		
16 hours, 300°C, 50 N/mm ²	MPa	22
16 hours, 175°C, 50 N/mm ²	MPa	28
Thickness increase ASTM F146:		
1) Oil IRM 903, 5h, 150°C	%	5
2) ASTM Fuel B, 5h, 23°C	%	5
3) Distilled water, 5h, 100°C	%	2
Max Operating conditions:		
Peak Temperature	°C	350
Continuous Temperature	°C	250
Continuous Temperature with Steam	°C	220
Pressure	MPa	10

Sizes available

Thicknesses (tolerance +/- 10%)
(mm) da 0,50 fino a 5,00
(inch) da 1/64" a 7/32"

Formats (tolerance +/- 5%)
(mm) 1.500 x 1.500 e 1.500 x 3.000
(inch) 60" x 60" ÷ 60" x 120"

Contact Carrara's technical office for information on gasket torque factors.

We assume no responsibility for errors due to wrong selection and inappropriate use of the material.

WARNING: The data shown in the tables refer to a typical behaviour of the materials and are the result of laboratory and factory tests carried out over the years. The specifications shown can change without notification. Wrong selection of the material for the specific application or improper use can cause damage to property and people. We assume no responsibility for errors due to wrong selection and inappropriate use of the material.

Typical values for 1.50 mm thickness

PLANIFLEX® COMPRESSED SHEETS - CSF



PF63

PLANIFLEX® PF63

Planiflex® PF63 is made of aramid fibres and NBR binder for general applications.

Color	Blue	
Binder	NBR	
Density	g/cm ³	1.9
Tensile strength DIN 52910	N/mm ²	6
Compressibility ASTM F36	%	11
Recovery ASTM F36	%	50
Residual stress DIN 52913:		
16 hours, 300°C, 50 N/mm ²	MPa	
16 hours, 175°C, 50 N/mm ²	MPa	25
Thickness increase ASTM F146:		
1) Oil IRM 903, 5h, 150°C	%	12
2) ASTM Fuel B, 5h, 23°C	%	
3) Distilled water, 5h, 100°C	%	
Max Operating conditions:		
Peak Temperature	°C	250
Continuous Temperature	°C	180
Continuous Temperature with Steam	°C	150
Pressure	MPa	5



PF41

PLANIFLEX® PF41

Planiflex® PF41 is made of organic fibres and NBR binder for general applications at low temperatures.

Color	Green	
Binder	NBR	
Density	g/cm ³	1.9
Tensile strength DIN 52910	N/mm ²	8
Compressibility ASTM F36	%	9
Recovery ASTM F36	%	60
Residual stress DIN 52913:		
16 hours, 300°C, 50 N/mm ²	MPa	
16 hours, 175°C, 50 N/mm ²	MPa	20
Thickness increase ASTM F146:		
1) Oil IRM 903, 5h, 150°C	%	10
2) ASTM Fuel B, 5h, 23°C	%	10
3) Distilled water, 5h, 100°C	%	
Max Operating conditions:		
Peak Temperature	°C	180
Continuous Temperature	°C	140
Continuous Temperature with Steam	°C	120
Pressure	MPa	4



PF81R

PLANIFLEX® PF81R

Planiflex® PF81R is made of aramid fibres, graphite and NBR binder and a metal mesh to withstand pressure.

Color	Black	
Binder	NBR	
Density	g/cm ³	2.3
Tensile strength DIN 52910	N/mm ²	10
Compressibility ASTM F36	%	11
Recovery ASTM F36	%	50
Residual stress DIN 52913:		
16 hours, 300°C, 50 N/mm ²	MPa	22
16 hours, 175°C, 50 N/mm ²	MPa	28
Thickness increase ASTM F146:		
1) Oil IRM 903, 5h, 150°C	%	5
2) ASTM Fuel B, 5h, 23°C	%	5
3) Distilled water, 5h, 100°C	%	2
Max Operating conditions:		
Peak Temperature	°C	350
Continuous Temperature	°C	250
Continuous Temperature with Steam	°C	220
Pressure	MPa	10



PF41G

PLANIFLEX® PF41G

Planiflex® PF41G is made of organic fibres, NBR binder and surface graphite.

Color	Black	
Binder	NBR	
Density	g/cm ³	1.9
Tensile strength DIN 52910	N/mm ²	8
Compressibility ASTM F36	%	9
Recovery ASTM F36	%	60
Residual stress DIN 52913:		
16 hours, 300°C, 50 N/mm ²	MPa	
16 hours, 175°C, 50 N/mm ²	MPa	20
Thickness increase ASTM F146:		
1) Oil IRM 903, 5h, 150°C	%	10
2) ASTM Fuel B, 5h, 23°C	%	10
3) Distilled water, 5h, 100°C	%	
Max Operating conditions:		
Peak Temperature	°C	180
Continuous Temperature	°C	140
Continuous Temperature with Steam	°C	120
Pressure	MPa	12



PF41RG

PLANIFLEX® PF41RG

Planiflex® PF41RG is made of organic fibres, NBR binder, metal mesh and surface graphite.

Color	Black	
Binder	NBR	
Density	g/cm ³	2.3
Tensile strength DIN 52910	N/mm ²	10
Compressibility ASTM F36	%	9
Recovery ASTM F36	%	55
Residual stress DIN 52913:		
16 hours, 300°C, 50 N/mm ²	MPa	
16 hours, 175°C, 50 N/mm ²	MPa	20
Thickness increase ASTM F146:		
1) Oil IRM 903, 5h, 150°C	%	10
2) ASTM Fuel B, 5h, 23°C	%	10
3) Distilled water, 5h, 100°C	%	
Max Operating conditions:		
Peak Temperature	°C	180
Continuous Temperature	°C	140
Continuous Temperature with Steam	°C	120
Pressure	MPa	12

Sizes available

Thicknesses (tolerance +/- 5%)
(mm) 0,50 ÷ 0,80 ÷ 1,00 ÷ 1,50 ÷ 2,00 ÷ 2,50 ÷ 3,00 ÷ 4,00 ÷ 5,00

(inch) 1/64" ÷ 1/32" ÷ 3/64" ÷ 1/16" ÷ 5/64" ÷ 3/32" ÷ 1/8" ÷ 5/32" ÷ 3/16"

Dimensions (+/- 5% tolerance)

(mm) 1.500 x 1.500 ÷ 1.500 x 3.000

(inch) 60" x 60" ÷ 60" x 120"

For each item of the Planiflex® family the reinforced version R is available.

Contact Carrara's technical office for information on gasket torque factors.

We assume no responsibility for errors due to wrong selection and inappropriate use of the material.

WARNING: The data shown in the tables refer to a typical behaviour of the materials and are the result of laboratory and factory tests carried out over the years. The specifications shown can change without notification. Wrong selection of the material for the specific application or improper use can cause damage to property and people. We assume no responsibility for errors due to wrong selection and inappropriate use of the material.

Typical values for 1.50 mm thickness

PLANIX®

RUBBER GASKET SHEETS



PLANIX 01

PAPER BOARD

Planix® PX01 is a thermal insulating cardboard material made entirely of asbestos-free and ceramic-free.

	UM	
Color	--	Beige
Specific Gravity	g/cm ³	0.95 ± 0.05
Thickness	mm	2.0 to 10.0
Width	m	1.0
Length	m	1.0
Hardness	Shore A	--
Operating Temperature	°C	750
Tensile Strength	MPa	3.5
Elongation	%	--
Tear Resistance	N/mm	--
Compression Set (22 hrs at 70°C)	%	--



PLANIX 02

POLIETILENE

Planix® PX02 PE HD Polyethylene has a high resistance to chemicals and displays good electrical properties.

	UM	
Color	--	White
Specific Gravity	g/cm ³	0.95 ± 0.05
Thickness	mm	1.0 to 30.0
Width	m	1.0
Length	m	2.0
Hardness	Shore A	63 ± 5
Operating Temperature	°C	-30 ÷ 80
Tensile Strength	MPa	20.0
Elongation	%	200
Tear Resistance	N/mm	--
Compression Set (22 hrs at 70°C)	%	--



PLANIX 03

EPDM RUBBER

Planix PX03 EPDM is a family of synthetic rubbers belonging to group M according to DIN/ISO 1629 classification.

	UM	
Color	--	Black
Specific Gravity	g/cm ³	1.25 ± 0.05
Thickness	mm	1.0 to 50.0
Width	m	1.2
Length	m	1.2 to 10.0
Hardness	Shore A	60 ± 5
Operating Temperature	°C	-25 ÷ 120
Tensile Strength	MPa	4.0
Elongation	%	200
Tear Resistance	N/mm	10
Compression Set (22 hrs at 70°C)	%	40



PLANIX 04

FLEXOID®

FLEXOID® Planix PX04 is a cellulose-based material impregnated with plasticised gelatin.

	UM	
Color	--	Light Beige
Specific Gravity	g/cm ³	0.70 ± 0.05
Thickness	mm	0.0 to 2.0
Width	m	1.0
Length	m	5.0
Hardness	Shore A	--
Operating Temperature	°C	-20 ÷ 120
Tensile Strength	MPa	16.0
Elongation	%	--
Tear Resistance	N/mm	--
Compression Set (22 hrs at 70°C)	%	--



PLANIX 05

WHITE SBR RUBBER

Planix® PX05 white SBR food grade rubber can be used with non-liquid, oily or greasy food substances.

	UM	
Color	--	White
Specific Gravity	g/cm ³	1.5 ± 0.05
Thickness	mm	1.0 to 50.0
Width	m	1.2
Length	m	1.2 to 10.0
Hardness	Shore A	60 ± 5
Operating Temperature	°C	-25 ÷ 120
Tensile Strength	MPa	8.0
Elongation	%	400
Tear Resistance	N/mm	15
Compression Set (22 hrs at 70°C)	%	40



PLANIX 07

CSM RUBBER

Planix® PX07 is a sheet or roll in CSM Chloro-Sulphenated Polyethylene rubber.

	UM	
Color	--	Black
Specific Gravity	g/cm ³	1.4 ± 0.03
Thickness	mm	1.0 to 50.0
Width	m	1.2
Length	m	1.2 to 10.0
Hardness	Shore A	70 ± 5
Operating Temperature	°C	-35 ÷ 140
Tensile Strength	MPa	7.0
Elongation	%	400
Tear Resistance	N/mm	17
Compression Set (22 hrs at 70°C)	%	40

Thicknesses Tolerance +/- 10%, Dimensions Tolerance +/- 5%



PLANIX - RUBBER GASKET SHEETS



PLANIX 08

NBR RUBBER

Planix® PX08 is a gasket sheet in NBR nitrile rubber also known as BUNA N.

	UM	
Color	--	Black
Specific Gravity	g/cm ³	1.24 ± 0.03
Thickness	mm	1.0 to 50.0
Width	m	1.2
Length	m	1.2 to 10.0
Hardness	Shore A	70 ± 5
Operating Temperature	°C	-25 ÷ 120
Tensile Strength	MPa	14.0
Elongation	%	300
Tear Resistance	N/mm	55
Compression Set (22 hrs at 70°C)	%	20



PLANIX 09

CHLOROPRENE RUBBER

Planix® PX09 is a gasket sheet in CR chloroprene and has a good compatibility with oils and fuels.

	UM	
Color	--	Black
Specific Gravity	g/cm ³	1.5 ± 0.03
Thickness	mm	1.0 to 50.0
Width	m	1.2
Length	m	1.2 to 10.0
Hardness	Shore A	60 ± 5
Operating Temperature	°C	-20 ÷ 100
Tensile Strength	MPa	4.5
Elongation	%	250
Tear Resistance	N/mm	12
Compression Set (22 hrs at 70°C)	%	35



PLANIX 11

NR RUBBER

Planix® PX11 is a gasket sheet made of natural NR rubber that displays excellent elasticity and compressibility.

	UM	
Color	--	Black
Specific Gravity	g/cm ³	0.97 ± 0.03
Thickness	mm	1.0 to 50.0
Width	m	1.2
Length	m	1.2 to 10.0
Hardness	Shore A	40 ± 5
Operating Temperature	°C	-35 ÷ 70
Tensile Strength	MPa	20.0
Elongation	%	550
Tear Resistance	N/mm	40
Compression Set (22 hrs at 70°C)	%	40



PLANIX 15

SBR RUBBER

Planix® PX15 is a gasket sheet in SBR styrenic rubber suitable for general use.

	UM	
Color	--	Black
Specific Gravity	g/cm ³	1.5 ± 0.03
Thickness	mm	1.0 to 50.0
Width	m	1.2
Length	m	1.2 to 10.0
Hardness	Shore A	70 ± 5
Operating Temperature	°C	-25 ÷ 70
Tensile Strength	MPa	4.0
Elongation	%	200
Tear Resistance	N/mm	14
Compression Set (22 hrs at 70°C)	%	40



PLANIX 17

SILICONE RUBBER

Planix® PX17 is a odourless and stain-proof red silicone rubber gasket sheet.

	UM	
Color	--	Red
Specific Gravity	g/cm ³	1.25 ± 0.03
Thickness	mm	1.0 to 50.0
Width	m	1.0
Length	m	1.0
Hardness	Shore A	60 ± 5
Operating Temperature	°C	-70 ÷ 200
Tensile Strength	MPa	7.0
Elongation	%	300
Tear Resistance	N/mm	20
Compression Set (22 hrs at 70°C)	%	34



PLANIX 19

FKM RUBBER

Planix® PX19 is a FKM rubber gasket sheet particularly suitable for oil industry.

	UM	
Color	--	Black
Specific Gravity	g/cm ³	1.5 ± 0.03
Thickness	mm	1.0 to 50.0
Width	m	1.2
Length	m	1.2 to 10.0
Hardness	Shore A	70 ± 5
Operating Temperature	°C	-30 ÷ 250
Tensile Strength	MPa	7.5
Elongation	%	250
Tear Resistance	N/mm	18
Compression Set (22 hrs at 70°C)	%	62

Thicknesses Tolerance +/- 10%, Dimensions Tolerance +/- 5%

The 5 steps for a perfect seal!

For a safe, efficient and long-lasting seal it is essential to select the correct material followed by correct installation that will ensure the best gasket performs.

Step 1 Cleaning and inspection

All residues must be removed from surfaces and rods this cleaning allows to check their condition.

Step 2 Check the alignment of flanges

Any misalignment of flanges compromises the quality of the seal.

Step 3 Installation of the gasket

The gasket must be of the correct size, undamaged and well-centred before starting tightening operations.

Step 4 Tie-rod lubrication

Lubrication of tie rods must be carried out with suitable materials and ensuring not to contaminate the gasket.

Step 5 Tightening of the tie rods

Tightening must be done in the correct sequence, taking care never to exceed the gasket damage limit.

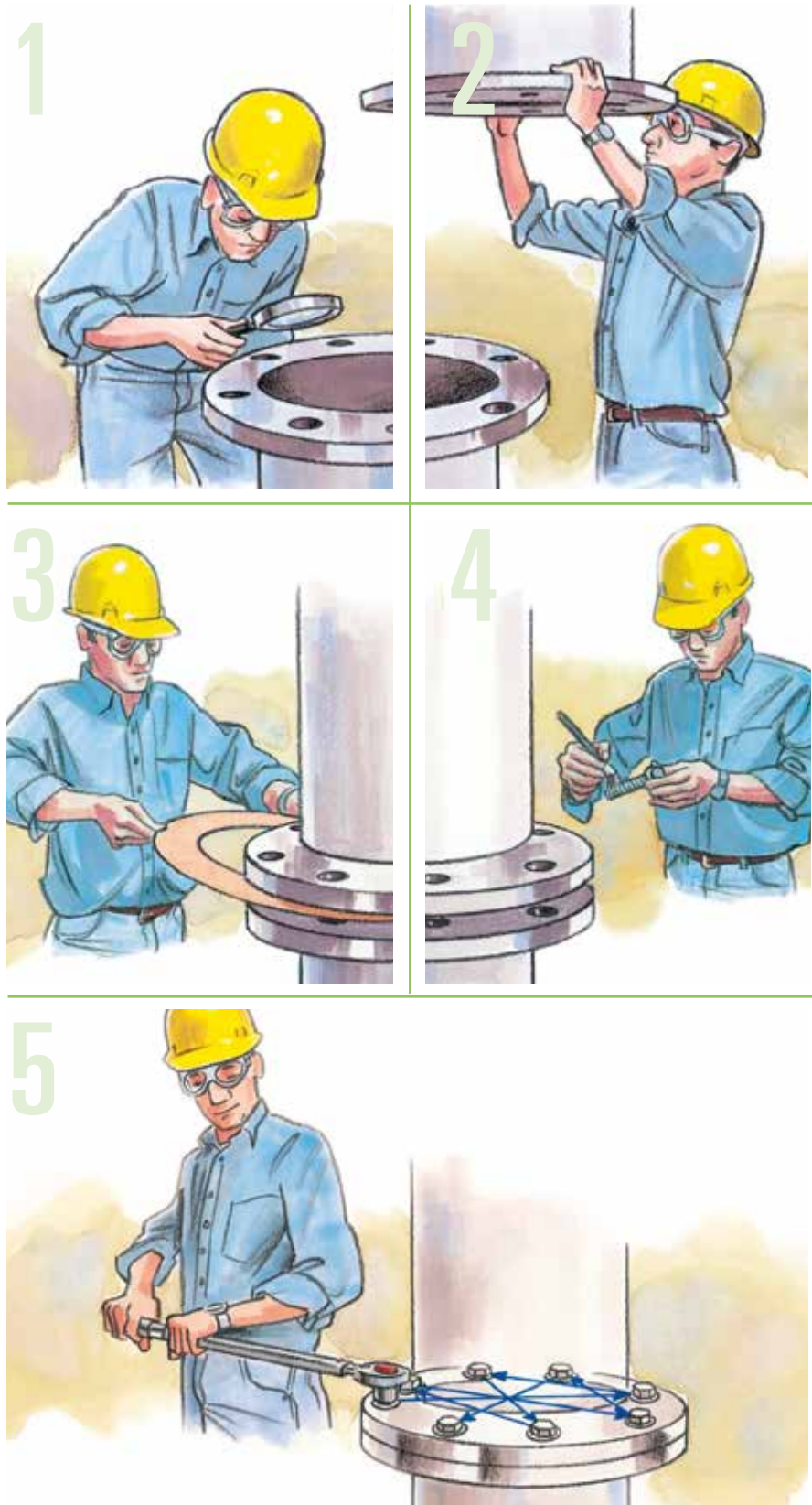

Chemical Resistance Chart

Chemical Compatibility Chart provides only general indications for material selection. Its use must always be accompanied by a specific application inspection and indications derived from the experience of using the gaskets at the factory.



All the information and data cited are based on the years of experience in sealing applications and must be considered to be entirely indicative. The data can not be used for warranty claims. Carrara S.p.a. can make changes to the compatibility table without prior notice and any obligation to provide notice.

	PF 64	PF 65	PF 81F	PF 13	PF 81	PF 63	PF 41	PF 81R	B13	B14	B15	E12	Graphite
Acetamide	A	A	A	A	A	A	A	A	A	A	A	A	A
Acetic acid 10%	A	A	A	A	A	A	A	A	A	A	A	A	A
Acetic acid 100%	C	C	C	C	C	C	C	C	B	B	B	B	A
Acetone	B	B	B	B	B	B	B	B	A	A	A	A	A
Acetonitrile	C	C	C	C	C	C	C	C	A	A	A	A	A
Acetylene (gas)	A	A	A	A	A	A	A	A	A	A	A	A	A
Adipic acid	A	A	A	A	A	A	A	A	A	A	A	A	A
Air	A	A	A	A	A	A	A	A	A	A	A	A	B
Alums	A	A	A	A	A	A	A	A	A	A	A	A	A
Aluminum acetate	A	A	A	A	A	A	A	A	A	A	A	A	A
Aluminum chlorate	B	B	B	B	B	B	B	B	A	A	A	A	A
Aluminum chloride	B	B	B	B	B	B	B	B	A	A	A	A	A
Ammonia (gas)	B	B	B	B	B	B	B	B	A	A	A	A	A
Ammonium bicarbonate	A	A	A	A	A	A	A	A	A	A	A	A	A
Ammonium chloride	A	A	A	A	A	A	A	A	A	A	A	A	A
Ammonium hydroxide	A	A	A	A	A	A	A	A	A	A	A	A	A
Amyl acetate	B	B	B	B	B	B	B	B	A	A	A	A	A
Aniline	C	C	C	C	C	C	C	C	A	A	A	A	A
Asphalt	A	A	A	A	A	A	A	A	A	A	A	A	A
Barium chloride	A	A	A	A	A	A	A	A	A	A	A	A	A
Benzene	A	A	A	A	A	A	A	A	A	A	A	A	A
Benzoic acid	B	B	B	B	B	B	B	B	A	A	A	A	A
Boric acid	A	A	A	A	A	A	A	A	A	A	A	A	A
Borax	A	A	A	A	A	A	A	A	A	A	A	A	A
Butane	A	A	A	A	A	A	A	A	A	A	A	A	A
Butyl alcohol (Butanol)	A	A	A	A	A	A	A	A	A	A	A	A	A
Butyric acid	A	A	A	A	A	A	A	A	A	A	A	A	A
Calcium chloride	A	A	A	A	A	A	A	A	A	A	A	A	A
Calcium hydroxide	A	A	A	A	A	A	A	A	A	A	A	A	A
Carbon monoxide	A	A	A	A	A	A	A	A	A	A	A	A	A
Carbon dioxide	A	A	A	A	A	A	A	A	A	A	A	A	A
Chloroform	C	C	C	C	C	C	C	C	A	A	A	A	A
Chloryne, (gas)	C	C	C	C	C	C	C	C	A	A	A	A	C
Chloryne, (in water)	C	C	C	C	C	C	C	C	A	A	A	A	C
Chromic acid	C	C	C	C	C	C	C	C	A	A	A	A	A
Citric acid	B	B	B	B	B	B	B	B	A	A	A	A	A
Copper acetate	A	A	A	A	A	A	A	A	A	A	A	A	B
Creosote	B	B	B	B	B	B	B	B	A	A	A	A	B
Cresol	C	C	C	C	C	C	C	C	A	A	A	A	A
Cyclohexane	A	A	A	A	A	A	A	A	A	A	A	A	A
Cyclohexanone	B	B	B	B	B	B	B	B	A	A	A	A	A
Decaline	A	A	A	A	A	A	A	A	A	A	A	A	A
Dibenzylether	B	B	B	B	B	B	B	B	A	A	A	A	A
Dimethylacetamide	B	B	B	B	B	B	B	B	A	A	A	A	A
Dimethylformamide	B	B	B	B	B	B	B	B	A	A	A	A	A
Ethane	A	A	A	A	A	A	A	A	A	A	A	A	A
Ethyl acetate	B	B	B	B	B	B	B	B	A	A	A	A	A
Ethyl Alcohol (Ethanol)	A	A	A	A	A	A	A	A	A	A	A	A	A
Ethyl chloride (gas)	C	C	C	C	C	C	C	C	A	A	A	A	A
Ethylene (gas)	A	A	A	A	A	A	A	A	A	A	A	A	A
Ethylene glycol	A	A	A	A	A	A	A	A	A	A	A	A	A
Formic acid 10%	A	A	A	A	A	A	A	A	A	A	A	A	A
Formic acid 85%	B	B	B	B	B	B	B	B	A	A	A	A	A
Formaldehyde	B	B	B	B	B	B	B	B	B	B	B	B	A
Freon 12	A	A	A	A	A	A	A	A	A	A	A	A	A
Freon 22	B	B	B	B	B	B	B	B	A	A	A	A	A
Fuel oil	A	A	A	A	A	A	A	A	A	A	A	A	A
Gasoline	A	A	A	A	A	A	A	A	A	A	A	A	A
Glycerine	A	A	A	A	A	A	A	A	A	A	A	A	A
Heptane	A	A	A	A	A	A	A	A	A	A	A	A	A
Hydraulic oil (mineral)	A	A	A	A	A	A	A	A	A	A	A	A	A
Hydraulic oil (Phosphate ester type)	B	B	B	B	B	B	B	B	A	A	A	A	A
Hydraulic (Glycol based)	A	A	A	A	A	A	A	A	A	A	A	A	A
Hydrazine	C	C	C	C	C	C	C	C	A	A	A	A	A
Hydrochloric acid 10%	B	B	B	B	B	B	B	B	A	A	A	A	A
Hydrochloric acid 37%	C	C	C	C	C	C	C	C	A	A	A	A	B
Hydrofluoric acid 10%	C	C	C	C	C	C	C	C	A	A	A	A	C

Temperature, pressure and pH.

In order to select the most suitable material for the specific application, temperature, pressure and pH must always be taken into account together.



It is always a priority to check that the material can be used at the operating temperature.



Chemical compatibility verification must consider the actual operating temperature.

As pressure increases, the stress inside the gasket increases. High temperatures and aggressive chemical environments can reduce the mechanical resistance of some types of gaskets.

 Recommended

 Recommendation depends on operating conditions

 Not recommended

	PF64	PF65	PF81F	PF13	PF81	PF63	PF41	PF81R	B13	B14	B15	E12	Graphite
Hydrofluoric acid 40%	C	C	C	C	C	C	C	C	A	A	A	A	C
Hydrogen	A	A	A	A	A	A	A	A	A	A	A	A	A
Isobutane	A	A	A	A	A	A	A	A	A	A	A	A	A
Isooctane	A	A	A	A	A	A	A	A	A	A	A	A	A
Isopropyl alcohol (Isopropanol)	A	A	A	A	A	A	A	A	A	A	A	A	A
Kerosene	A	A	A	A	A	A	A	A	A	A	A	A	A
Ketones	B	B	B	B	B	B	B	B	A	A	A	A	A
Lactic acid	B	B	B	B	B	B	B	B	A	A	A	A	A
Magnesium sulfate	A	A	A	A	A	A	A	A	A	A	A	A	A
Maleic acid	B	B	B	B	B	B	B	B	A	A	A	A	A
Methane	A	A	A	A	A	A	A	A	A	A	A	A	A
Methyl alcohol (Methanol)	A	A	A	A	A	A	A	A	A	A	A	A	A
Methyl chloride (gas)	B	B	B	B	B	B	B	B	A	A	A	A	A
Methylene dichloride	B	B	B	B	B	B	B	B	A	A	A	A	A
Methyl Ethyl Ketone (MEK)	B	B	B	B	B	B	B	B	A	A	A	A	A
N-Methyl-pyrrolidone (NMP)	B	B	B	B	B	B	B	B	A	A	A	A	A
Milk	A	A	A	A	A	A	A	A	A	A	A	A	A
Mineral oil type ASTM no. 1	A	A	A	A	A	A	A	A	A	A	A	A	A
Naphtha	A	A	A	A	A	A	A	A	A	A	A	A	A
Nitric acid 10%	C	C	C	C	C	C	C	C	A	A	A	A	B
Nitric acid 65%	C	C	C	C	C	C	C	C	A	A	A	A	C
Nitrobenzene	C	C	C	C	C	C	C	C	A	A	A	A	A
Nitrogen (gas)	A	A	A	A	A	A	A	A	A	A	A	A	A
Octane	A	A	A	A	A	A	A	A	A	A	A	A	A
Oleic acid	A	A	A	A	A	A	A	A	A	A	A	A	A
Oleum	C	C	C	C	C	C	C	C	A	C	C	A	C
Oxalic acid	B	B	B	B	B	B	B	B	A	A	A	A	A
Oxygen (Gas)	C	C	C	C	C	C	C	C	A	C	C	C	B
Palmitic acid	A	A	A	A	A	A	A	A	A	A	A	A	A
Pentane	A	A	A	A	A	A	A	A	A	A	A	A	A
Perchloroethylene	C	C	C	C	C	C	C	C	A	A	A	A	A
Phenol (Carbolic acid)	C	C	C	C	C	C	C	C	A	A	A	A	A
Phosphoric acid	C	C	C	C	C	C	C	C	C	C	A	A	A
Potassium acetate	A	A	A	A	A	A	A	A	A	A	A	A	A
Potassium bicarbonate	A	A	A	A	A	A	A	A	A	A	A	A	A
Potassium carbonate	A	A	A	A	A	A	A	A	A	A	A	A	A
Potassium chloride	A	A	A	A	A	A	A	A	A	A	A	A	A
Potassium dichromate	B	B	B	B	B	B	B	B	A	A	A	A	B
Potassium hydroxide	B	B	B	B	B	B	B	B	C	B	B	B	A
Potassium iodide	A	A	A	A	A	A	A	A	A	A	A	A	A
Potassium nitrate	A	A	A	A	A	A	A	A	A	A	A	A	C
Potassium permanganate	B	B	B	B	B	B	B	B	A	A	A	A	A
Propane	A	A	A	A	A	A	A	A	A	A	A	A	A
Pyridine	C	C	C	C	C	C	C	C	A	A	A	A	A
Salicylic acid	B	B	B	B	B	B	B	B	A	A	A	A	A
Silicones (oil, grease)	A	A	A	A	A	A	A	A	A	A	A	A	A
Soap	A	A	A	A	A	A	A	A	A	A	A	A	A
Sodium aluminate	A	A	A	A	A	A	A	A	A	A	A	A	A
Sodium bicarbonate	A	A	A	A	A	A	A	A	A	A	A	A	A
Sodium bisulphite	A	A	A	A	A	A	A	A	A	A	A	A	A
Sodium carbonate	A	A	A	A	A	A	A	A	A	A	A	A	A
Sodium chloride	A	A	A	A	A	A	A	A	A	A	A	A	A
Sodium cyanide	A	A	A	A	A	A	A	A	C	C	A	A	A
Sodium hydroxide	B	B	B	B	B	B	B	B	C	B	B	B	A
Sodium sulfate	A	A	A	A	A	A	A	A	A	A	A	A	A
Sodium sulfide	A	A	A	A	A	A	A	A	A	A	A	A	A
Starch	A	A	A	A	A	A	A	A	A	A	A	A	B
Steam	A	A	A	A	A	A	A	A	A	A	A	A	A
Stearic acid	A	A	A	A	A	A	A	A	A	A	A	A	A
Sugar	A	A	A	A	A	A	A	A	A	A	A	A	A
Sulphuric acid 20%	C	C	C	C	C	C	C	C	A	A	A	A	A
Sulphuric acid 96%	C	C	C	C	C	C	C	C	A	B	B	A	B
Tar	A	A	A	A	A	A	A	A	A	A	A	A	B
Tartaric acid	B	B	B	B	B	B	B	B	A	A	A	A	B
Toluene	A	A	A	A	A	A	A	A	A	A	A	A	A
Transformer oil (mineral type)	A	A	A	A	A	A	A	A	A	A	A	A	A
Trichloroethylene	C	C	C	C	C	C	C	C	A	A	A	A	A

DIMENSION TABLES

The main dimensional standards of flat gaskets are the following:

- ASME B16.21 relating to flanges
 - ASME 16.1
 - ASME B16.5
 - ASME B16.24
 - ASME B16.47 Series A
 - ASME B16.47 Series B
 - MSS SP-51
- EN 1514-1 relating to flanges
 - EN 1092-1
 - EN 1092-2
 - EN 1092-3
 - EN 1094-4
- EN 12560-1 relating to flanges
 - EN 1759-1
 - EN 1759-2
 - EN 1759-3
 - EN 1759-4
- JIS B 2404 relating to flanges
 - JIS B 2220
 - JIS B 2238
 - JIS B 2239
 - JIS B 2240
- BS 3063 relating to flanges
 - BS10

The dimensions of gaskets are also related to the type of flange surface classified as:

- RF raised face
- FF flat face
- LTG large tongue & groove
- LMF large male & female

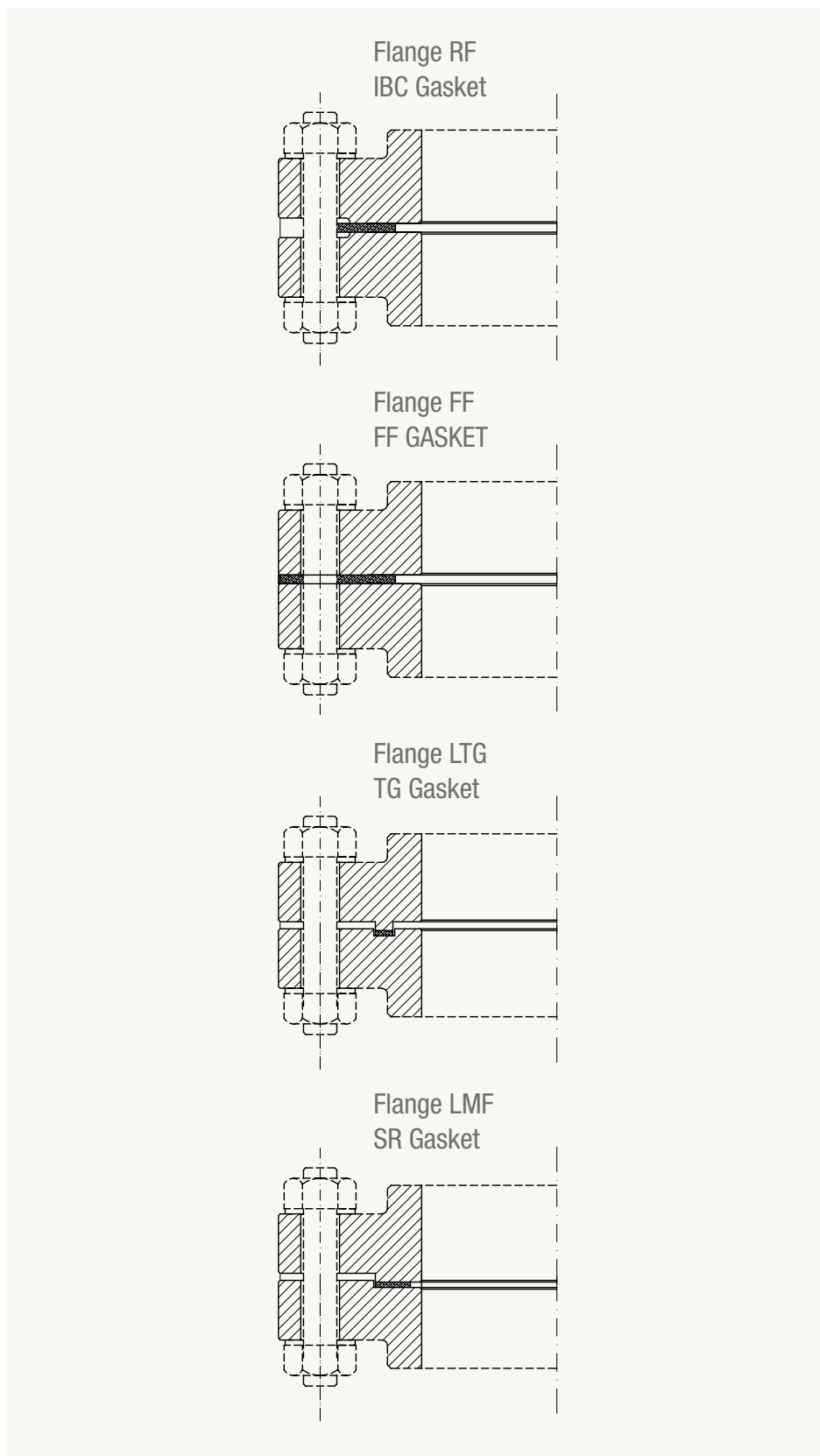



		FLAT GASKET DIMENSIONS for EN 1514-1										
		IBC								SR	TG	
		PN 2,5	PN 6	PN 10	PN 16	PN 25	PN 40	PN 63		PN 10-40	PN 10-40	
DN	Di	De						Di	De	De	Di	De
10	18	39	39	46	46	46	46	18	56	34	24	34
15	22	44	44	51	51	51	51	21	61	39	29	39
20	27	54	54	61	61	61	61	25	72	50	36	50
25	34	64	64	71	71	71	71	30	82	57	43	57
32	43	76	76	82	82	82	82	41	88	65	51	65
40	49	86	86	92	92	92	92	47	103	75	61	75
50	61	96	96	107	107	107	107	59	113	87	73	87
65	77	116	116	127	127	127	127	73	138	109	95	109
80	89	132	132	142	142	142	142	86	148	120	106	120
100	115	152	152	162	162	168	168	110	174	149	129	149
125	141	182	182	192	192	194	194	135	210	175	155	175
150	169	207	207	218	218	224	224	163	247	203	183	203
200	220	262	262	273	273	284	290	210	309	259	239	259
250	273	317	317	328	329	340	352	264	364	312	292	312
300	324	373	373	378	384	400	417	314	424	363	343	363
350	356	423	423	438	444	457	474	360	486	421	395	421
400	407	473	473	489	495	514	546	415	543	473	447	473
450	458	528	528	539	555	564	571			523	497	523
500	508	578	578	594	617	624	628			575	549	575
600	610	679	679	695	734	731	747			675	649	675
700	712	784	784	810	804	833						
800	813	890	890	917	911	942						
900	915	990	990	1017	1011	1042						
1000	1016	1090	1090	1124	1128	1154						
1100	1120			1231	1228	1254						
1200	1220	1290	1307	1341	1342	1364						
1400	1420	1490	1524	1548	1542	1578						
1500	1520			1658	1654	1688						
1600	1620	1700	1724	1772	1764	1798						
1800	1820	1900	1931	1972	1964	2000						
2000	2020	2100	2138	2182	2168	2230						
2200	2220	2307	2348	2384								
2400	2420	2507	2558	2594								
2600	2620	2707	2762	2794								
2800	2820	2924	2972	3014								
3000	3020	3124	3172	3228								
3200	3220	3324	3382									
3400	3420	3524	3592									
3600	3620	3734	3804									
3800	3820	3931										
4000	4020	4131										

DIMENSION TABLES



		FLAT GASKET DIMENSIONS for EN 12560-1 (ASME B16.21)							
		IBC (RF)					SR (LMF)	TG (LTG)	
		CL150	CL300	CL400	CL600	CL900	CL 150-1500	CL 150-1500	
NPS	Di	De					De	Di	De
1/2	21	48	54	54	54	64	35	25	35
3/4	27	57	67	67	67	70	43	33	43
1	33	67	73	73	73	79	51	38	51
1.1/4	42	76	83	83	83	89	64	47	64
1.1/2	48	86	95	95	95	98	73	54	73
2	60	105	111	111	111	143	92	73	92
2.1/2	73	124	130	130	130	165	105	85	105
3	89	137	149	149	149	168	127	108	127
4	114	175	181	178	194	206	157	132	157
5	141	197	216	213	241	248	186	160	186
6	168	222	251	248	267	289	216	190	216
8	219	279	308	305	321	359	270	238	270
10	273	340	362	359	400	435	324	286	324
12	324	410	422	419	457	498	381	343	381
14	356	451	486	483	492	521	413	374	413
16	406	514	540	537	565	575	470	425	470
18	457	549	597	594	613	638	533	489	533
20	508	606	654	648	683	699	584	533	584
24	610	718	775	768	791	838	692	641	692

		FLAT GASKET DIMENSIONS for ASME B16.47 A			
		IBC (RF)			
		CL150	CL300	CL400	CL600
NPS	Di	De			
26	660	775	835	832	867
28	711	832	899	892	914
30	762	883	953	946	972
32	813	940	1006	1003	1022
34	864	991	1057	1054	1073
36	914	1048	1118	1118	1130
38	965	1111	1054	1073	1105
40	1016	1162	1114	1127	1156
42	1067	1219	1165	1178	1219
44	1118	1276	1219	1232	1270
46	1168	1327	1273	1289	1327
48	1219	1384	1324	1346	1391
50	1270	1435	1378	1403	1448
52	1321	1492	1429	1454	1499
54	1372	1549	1492	1518	1556
56	1422	1607	1543	1568	1613
58	1473	1664	1594	1619	1664
60	1524	1715	1645	1683	1721

		FLAT GASKET DIMENSIONS for ASME B16.47 B			
		IBC (RF)			
		CL150	CL300	CL400	CL600
NPS	Di	De			
26	660	725	772	746	765
28	711	776	826	800	819
30	762	827	886	857	879
32	813	881	940	911	933
34	864	935	994	962	997
36	914	987	1048	1022	1048
38	965	1045	1099		
40	1016	1095	1149		
42	1067	1146	1200		
44	1118	1197	1251		
46	1168	1256	1318		
48	1219	1307	1368		
50	1270	1357	1419		
52	1321	1408	1470		
54	1372	1464	1530		
56	1422	1514	1594		
58	1473	1580	1656		
60	1524	1630	1705		

FULL FACE FF GASKET DIMENSIONS for EN 1514-1																					
		PN 2,5 / 6				PN 10				PN 16				PN 25				PN 40			
DN	Di	De	n	ø	DF ø	De	n	ø	DF ø	De	n	ø	DF ø	De	n	ø	DF ø	De	n	ø	DF ø
10	18	75	4	11	50	90	4	14	60	90	4	14	60	90	4	14	60	90	4	14	60
15	22	80	4	11	55	95	4	14	65	95	4	14	65	95	4	14	65	95	4	14	65
20	27	90	4	11	65	105	4	14	75	105	4	14	75	105	4	14	75	105	4	14	75
25	34	100	4	11	75	115	4	14	85	115	4	14	85	115	4	14	85	115	4	14	85
32	43	120	4	14	90	140	4	18	100	140	4	18	100	140	4	18	100	140	4	18	100
40	49	130	4	14	100	150	4	18	110	150	4	18	110	150	4	18	110	150	4	18	110
50	61	140	4	14	110	165	4	18	125	165	4	18	125	165	4	18	125	165	4	18	125
65	77	160	4	14	130	185	8	18	145	185	8	18	145	185	8	18	145	185	8	18	145
80	89	190	4	18	150	200	8	18	160	200	8	18	160	200	8	18	160	200	8	18	160
100	115	210	4	18	170	220	8	18	180	220	8	18	180	235	8	22	190	235	8	22	190
125	141	240	8	18	200	250	8	18	210	250	8	18	210	270	8	26	220	270	8	26	220
150	169	265	8	18	225	285	8	22	240	285	8	22	240	300	8	26	250	300	8	26	250
200	220	320	8	18	280	340	8	22	295	340	12	22	295	360	12	26	310	375	12	30	320
250	273	375	12	18	335	395	12	22	350	405	12	26	355	425	12	30	370	450	12	33	385
300	324	440	12	22	395	445	12	22	400	460	12	26	410	485	16	30	430	515	16	33	450
350	356	490	12	22	445	505	16	22	460	520	16	26	470	555	16	33	490	580	16	36	510
400	407	540	16	22	495	565	16	26	515	580	16	30	525	620	16	36	550	660	16	39	585
450	458	595	16	22	550	615	20	26	565	640	20	30	585	670	20	36	600	685	20	39	610
500	508	645	20	22	600	670	20	26	620	715	20	33	650	730	20	36	660	755	20	42	670
600	610	755	20	26	705	780	20	30	725	840	20	36	770	845	20	39	770	890	20	48	795
700	712					895	24	30	840	910	24	36	840	960	24	42	875				
800	813					1015	24	33	950	1025	24	39	950	1085	24	48	990				
900	915					1115	28	33	1050	1125	28	39	1050	1185	28	48	1090				
1000	1016					1230	28	36	1160	1255	28	42	1170	1320	28	56	1210				
1100	1120					1340	32	39	1270	1355	32	42	1270	1420	32	56	1310				
1200	1220					1455	32	39	1380	1485	32	48	1390	1530	32	56	1420				
1400	1420					1675	36	42	1590	1685	36	48	1590	1755	36	62	1640				
1500	1520					1785	36	42	1700	1820	36	56	1710	1865	36	62	1750				
1600	1620					1915	40	48	1820	1930	40	56	1820	1975	40	62	1860				
1800	1820					2115	44	48	2020	2130	44	56	2020	2195	44	70	2070				
2000	2020					2325	48	48	2230	2345	48	62	2230	2425	48	70	2300				

FULL FACE GASKET DIMENSIONS for EN 12560-1 (ASME B16.21)									
		CLASS 150				CLASS 300			
DN	Di	De	n	ø	DF ø	De	n	ø	DF ø
1/2	21	89	4	16	60	95	4	16	67
3/4	27	98	4	16	70	117	4	19	83
1	33	108	4	16	79	124	4	19	89
1.1/4	42	117	4	16	89	133	4	19	98
1.1/2	48	127	4	16	98	156	4	22	114
2	60	152	4	19	121	165	8	19	127
2.1/2	73	178	4	19	140	191	8	22	149
3	89	191	4	19	152	210	8	22	168
4	114	229	8	19	190	254	8	22	200
5	141	254	8	22	216	279	8	22	235
6	168	279	8	22	241	318	12	22	270
8	219	343	8	22	298	381	12	25	330
10	273	406	12	25	362				
12	324	483	12	25	432				



CARRARA, Global Sealing Solutions!

In addition to packing, Carrara offers a vast product range of high-quality gaskets for valves and flanges, together with all sealing accessories. The quality of the products, the professional technical and commercial assistance of the Team, the wide availability of stock and other tailor-made services reserved for Customer are the business guidelines to increase the value offered to Customers.



Setting Compression Packing Packings for valves and pumps

Carrara is among the leading manufacturers of packing and sealing systems for pumps and valves for all industrial applications. Thanks to the use of high quality yarns and special techniques developed by its R&D division, Carrara packings can offer high performance with an excellent quality-price ratio. Carrara sealing systems guarantee excellent sealing and emission control and can work at high pressures and speeds with any chemicals, reducing wear on shafts and bushings, and minimising maintenance.

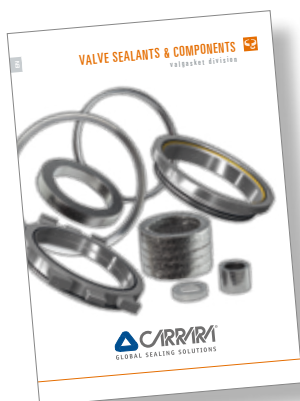

Valve Sealants & Sealing System Components for Valves

There is a complete product range of sealing system components for valves, which includes seats for ball valves, seats for gate valves, expanding gate valves and through conduit gate valves. Ring joint, spiral-wound, camprofile and flat gaskets for valves, o-rings and lip valves, together with a the range of Valvograph graphite products or stems, seats and closures that are Low Emission and Fire Safe qualified, and available in sizes from 8 mm up to 2,000 mm.



Setting Flange Planisteel® Metal Gaskets for Flange

Spirometallic, Camprofile, Ring Joint and Metal-Plastic for equipment and boilers are part of the Carrara Planisteel® range.

The STOCK LIST section of www.carrara.it allows you to check if these items are in stock in order to meet the growing demand for quick availability.



Setting Flange Insulating Sets per Flange

Insulating sets are used to prevent flow of electrostatic charges in the pipes. Carrara product range offers a wide range of Insulating Sets made of high performance materials, suitable for all pressure classes.



Setting Mechanical Seals Mechanical Seals for Pumps

Carrara product range offers a complete range of single cartridge mechanical seals with metal bellows, single cartridge with multiple stationary and rotary springs and split seals. Carrara Mechanical Seals are easy to install and guarantee low component management costs.



FERP Environmental Division

For over fifteen years, Carrara's FERP Environmental Division has been one of the main international leaders in monitoring fugitive and diffused VOC emissions, steam leaks, technical and auxiliary gas leaks, developing Energy Saving programmes and other high value-added services for Refining, Energy Production, Off Shore and Petrochemical sectors.



The data shown in the technical data sheets have been obtained from tests carried out at Carrara S.p.a laboratories, from tests performed at third-party laboratories and from the experience of using the products in industrial applications. Correct product selection and installation are determining factors for product functionality. Carrara S.p.a. assumes no responsibility for damage to property and persons caused by improper use, incorrect use or non-optimal use of its products. Carrara S.p.a. reserves the right to change the technical data shown in this catalogue without having to communicate any changes to third parties.

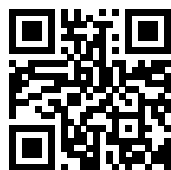

www.carrara.it

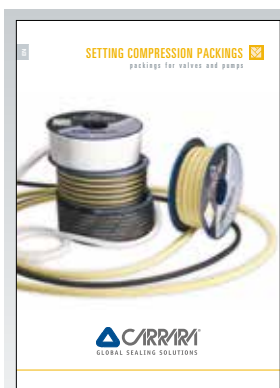

Braided Packings

A wide and certified product range of API 622, ISO 15848, BAM and FDA certified packing for all industrial applications.



Valve Components

Seats for soft or metallic sealing for ball and gate valves, seat/ball kit equipped with all gaskets.



Metallic Flange Gaskets

Planisteel is the range of Spirometallic, Kamprofile and Ring Joints gaskets in compliance with international standards or customised on demand.



Flat Gaskets for Flange

Planigraph, Planiflon and Planiflex gasket sheets and sealing gaskets for all applications.



Mechanical seals

The Single Stationary Multiples Springs Cartridge and Metal Bellows Single Cartridge mechanical seals are the main products in our range.

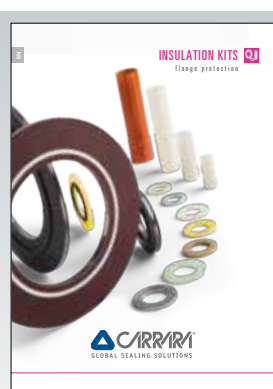

Insulation Kits

Flange insulation kits for cathodic protection are one of our specialities.



FERP Envir. Division

LDAR and SMART LDAR, monitoring of Tanks and steam systems, 3D environmental consulting.